



Version 1.2

# Reference Manual

## C AD 5320 D

Dual Analog Audio to AES Converter

Series 5000  
*CardModule*

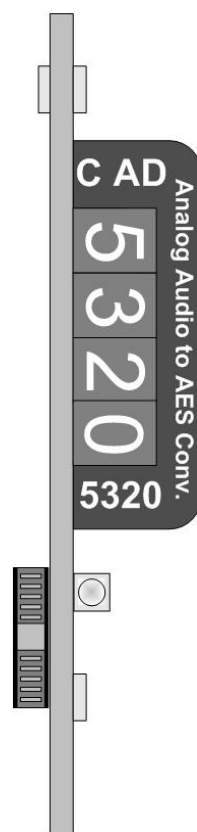
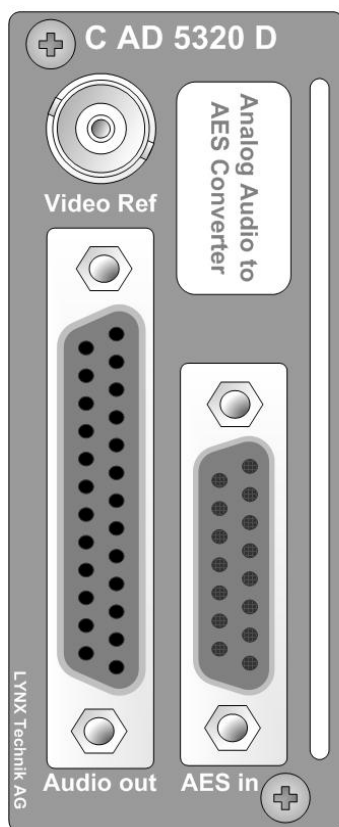

© LYNX Technik AG  
Brunnenweg 3  
D-64331 Weiterstadt  
Germany  
[www.lynx-technik.com](http://www.lynx-technik.com)

Information in this document is subject to change without notice. No part of this document may be reproduced or transmitted in any form or by any means, electronic or mechanical for any purpose, without express written permission of LYNX Technik AG.

LYNX Technik AG may have patents, patent applications, trademarks, copyrights or other intellectual property rights covering the subject matter in this document. Except as expressly written by LYNX Technik AG, the furnishing of this document does not give you any license to patents, trademarks, copyrights or other intellectual property of LYNX Technik AG or any of its affiliates.

© LYNX Technik AG 2003 all rights reserved

# Warranty

LYNX Technik AG warrants that the product will be free from defects in materials and workmanship for a period of two (2) year from the date of shipment. If this product proves defective during the warranty period, LYNX Technik AG at its option will either repair the defective product without charge for parts and labor, or will provide a replacement in exchange for the defective product.

In order to obtain service under this warranty, customer must notify LYNX Technik of the defect before expiration of the warranty period and make suitable arrangements for the performance of service. Customer shall be responsible for packaging and shipping the defective product to the service center designated by LYNX Technik, with shipping charges prepaid. LYNX Technik shall pay for the return of the product to the customer if the shipment is within the country which the LYNX Technik service center is located. Customer shall be responsible for payment of all shipping charges, duties, taxes and any other charges for products returned to any other locations.

This warranty shall not apply to any defect, failure, or damage caused by improper use or improper or inadequate maintenance and care. LYNX Technik shall not be obligated to furnish service under this warranty a) to repair damage resulting from attempts by personnel other than LYNX Technik representatives to install, repair or service the product; b) to repair damage resulting from improper use or connection to incompatible equipment; c) to repair any damage or malfunction caused by the use of non LYNX Technik supplies; or d) to service a product which has been modified or integrated with other products when the effect of such modification or integration increases the time or difficulty servicing the product.

**THIS WARRANTY IS GIVEN BY LYNX TECHNIK WITH RESPECT TO THIS PRODUCT IN LIEU OF ANY OTHER WARRANTIES, EXPRESS OR IMPLIED. LYNX TECHNIK AND ITS VENDORS DISCLAIM ANY IMPLIED WARRANTIES OF MERCHANTABILITY OR FITNESS FOR A PARTICULAR PURPOSE. LYNX TECHNIK`S RESPONSIBILITY TO REPAIR AND REPLACE DEFECTIVE PRODUCTS IS THE SOLE AND EXCLUSIVE REMEDY PROVIDED TO THE CUSTOMER FOR BREACH OF THIS WARRANTY. LYNX TECHNIK AND ITS VENDORS WILL NOT BE LIABLE FOR ANY INDIRECT, SPECIAL, INCIDENTAL, OR CONSEQUENTIAL DAMAGES IRRESPECTIVE OF WHETHER LYNX TECHNIK OR THE VENDOR HAS ADVANCE NOTICE OF THE POSSIBILITY OF SUCH DAMAGES.**

# Regulatory information

## Europe

### Declaration of Conformity

We	LYNX Technik AG Brunnenweg 3 D-64331 Weiterstadt Germany
<i>Declare under our sole responsibility that the product</i>	
TYPE: C AD 5320 D	
<i>To which this declaration relates is in conformity with the following standards (environments E1 – E3):</i>	
EN 55103-1 /1996	
EN 55103-2 /1996	
EN 60950 /2001	
<i>Following the provisions of 89/336/EEC and 73/23/EEC directives.</i>	
	Winfried Deckelmann
Weiterstadt, May 2004	
<i>Place and date of issue</i>	<i>Legal Signature</i>

## USA

### FCC 47 Part 15

This device complies with part 15 of the FCC Rules. Operation is subject to the following two conditions: (1) This device may not cause harmful interference, and (2) this device must accept any interference received, including interference that may cause undesired operation.

Note: This equipment has been tested and found to comply with the limits for a Class A digital device, pursuant to the part 15 of the FCC Rules. These limits are designed to provide reasonable protection against harmful interference when the equipment is operated in a commercial environment. This equipment generates, uses, and can radiate radio frequency energy and, if not installed and used in accordance with the instruction manual, may cause harmful interference to radio communications. Operation of this equipment in a residential area is likely to cause harmful interference in which case the user will be required to correct the interference at his own expense

---

# Contents

<b>Warranty</b> .....	<b>3</b>
<b>Regulatory information</b> .....	<b>4</b>
Europe .....	4
Declaration of Conformity .....	4
USA .....	4
FCC 47 Part 15.....	4
<b>Contents</b> .....	<b>5</b>
<b>Getting Started</b> .....	<b>7</b>
Packaging .....	7
Product Description .....	7
Functional Diagram.....	8
Module Layout .....	8
<b>Connections</b> .....	<b>10</b>
Audio Connections.....	10
Audio Input Connections (balanced).....	10
Audio Output Connector (balanced) .....	11
Audio Input Connections (un-balanced).....	11
<b>Installation</b> .....	<b>12</b>
<b>Settings and Control</b> .....	<b>13</b>
Multi Function Switch.....	14
Using the Local Display Menus.....	15
Navigation .....	15
Local Adjustments Available.....	15
Factory Default Values .....	15
Menu Structure .....	16
Auto Store .....	16
<b>Alarm/LED Status Indicators</b> .....	<b>20</b>
Channel Condition Indicators.....	20
Reference Status Indicator .....	20
Alarm Indicator .....	20
Locate Function .....	21
<b>Specifications (C AD 5320 D)</b> .....	<b>22</b>
<b>Available Options</b> .....	<b>23</b>
<b>Parts List</b> .....	<b>23</b>
<b>Service</b> .....	<b>24</b>
<b>Contact Information</b> .....	<b>25</b>

*This page is intentionally left blank*

# Getting Started

## Packaging

The shipping carton and packaging materials provide protection for the module during transit. Please retain the shipping cartons in case subsequent shipping of the product becomes necessary.

## Product Description

The C AD 5320 is a high quality dual channel analog audio to AES converter (A/D) and is designed primarily for broadcast and professional applications.

The module accepts balanced analog audio inputs and converts these to 24 bit AES digital streams. Sampling rates of 32 kHz, 44.1 kHz, 48 kHz and 96 kHz are supported. The converter can be locked to external video reference, external AES reference or internal reference. Input full scale ranging is adjustable and an internal test tone generator is also provided. AES outputs are isolated with transformers.

The C AD 5320 features a wide range of available adjustments (via optional Rack Controller). Basic adjustments are possible using via the local multi-function switch and integrated display.

CardModules are installed in the series 5000 card frame that can accommodate up to 10 CardModules. All modules are hot swappable and Options include full redundant power and a range of controller options.

## Functional Diagram

Figure 1 below is the basic functional diagram for the C AD 5320 CardModule.

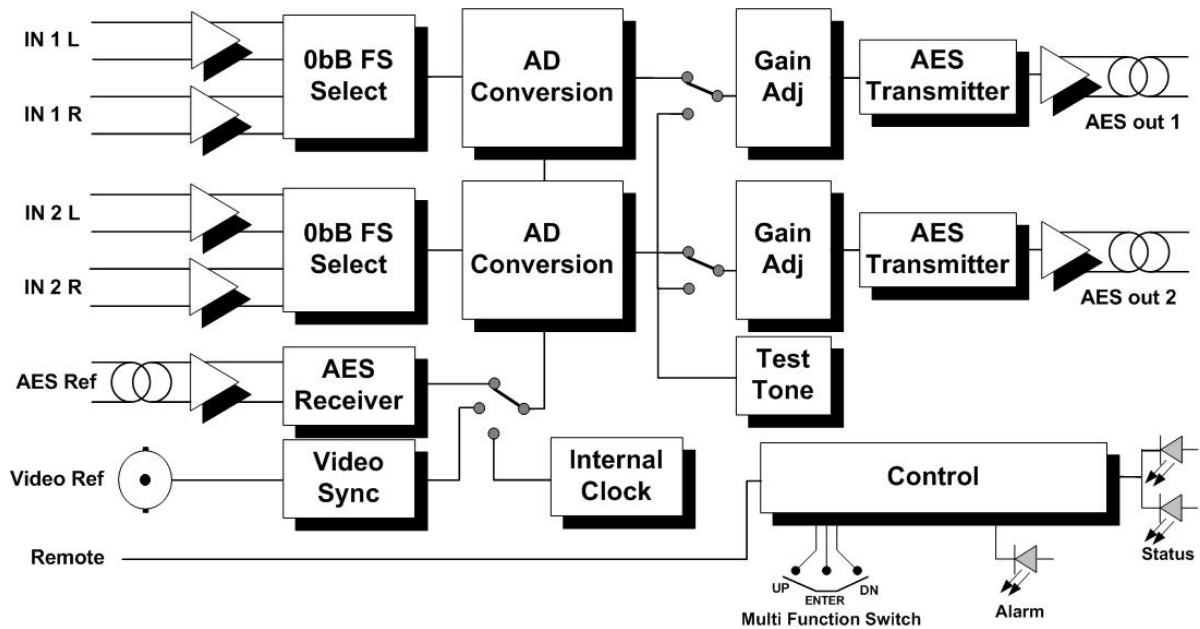

Figure 1- C AD 5320 Functional Diagram

## Module Layout

Figure 2 shows the physical layout of the C AD 5320 CardModule and also the connection panel which is fitted to the rear of the rack.



**PCB Layout**

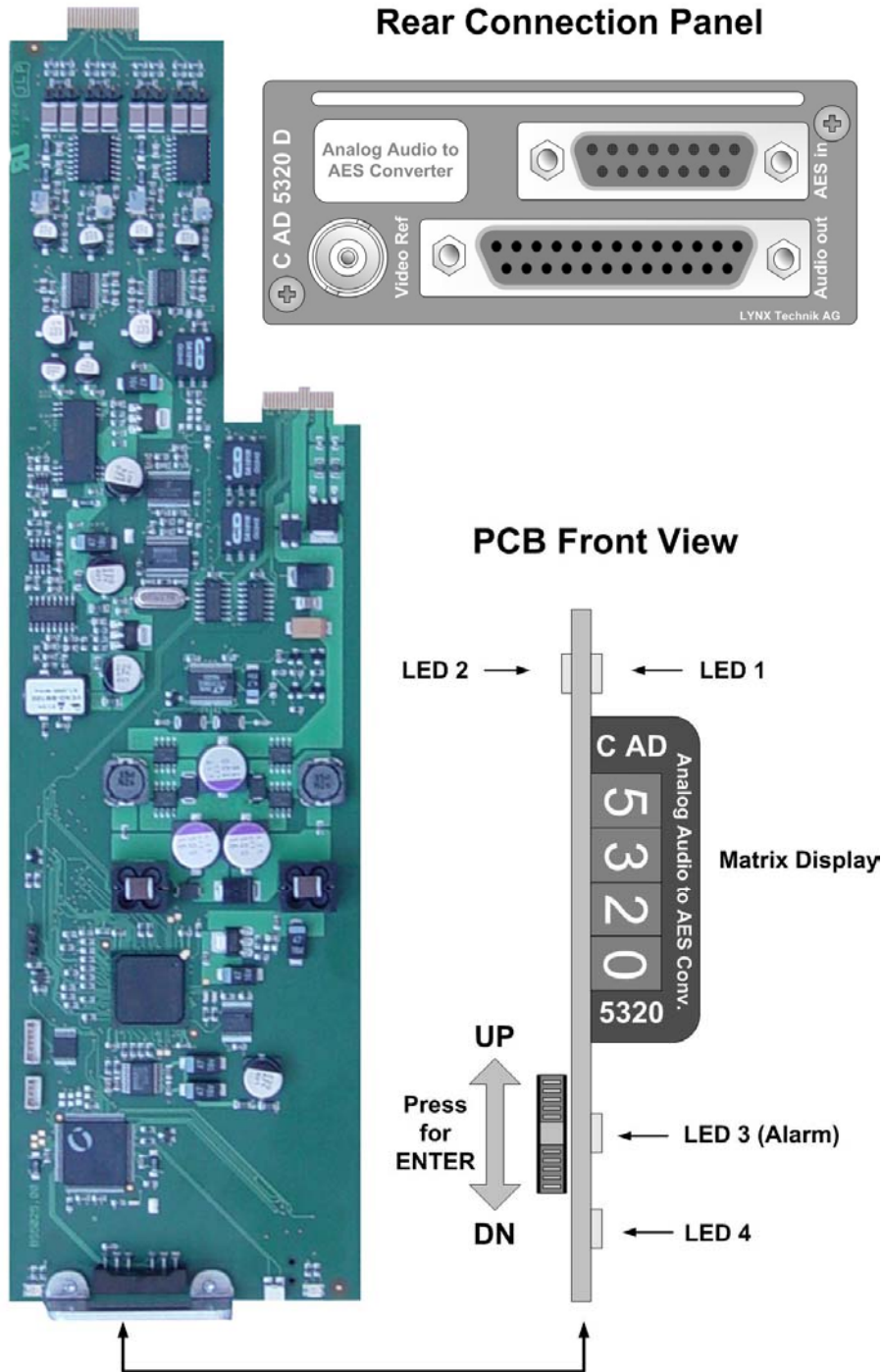

Figure 2 – Module Layout



**Caution**

Use static precautions when handling the PCB. Static discharge could result in serious damage to the module.

# Connections

## Audio Connections

The C AD 5320 D Module is configured for SubD audio connections for audio I/O and a BNC connector for video reference. The SubD connectors should be wired in accordance with the tables below. Please use high quality screened cable to prevent the introduction of noise and interference to the audio signals (twisted pair suitable for balanced audio signals).

### Audio Input Connections (balanced)

SubD 25 pin female connector. (TASCAM pinout)

Pin Number	Connection	Pin Number	Connection
1	+ IN Left 1	14	- IN Left 1
2	GND IN Left 1	15	+ IN Right 1
3	- IN Right 1	16	GND IN Right 1
4	+ IN Left 2	17	- IN Left 2
5	GND IN Left 2	18	+ IN Right 2
6	- IN Right 2	19	GND IN Right 2
7			
8			
9			
10			
11			
12			
13			

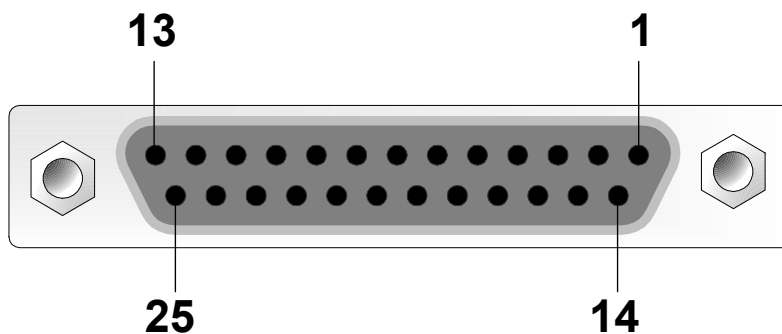

Figure 3 - Audio output connection detail

## Audio Output Connector (balanced)

SubD 15-pin female connector

Pin Number	Connection	Pin Number	Connection
1		9	
2		10	+ AES Ref in
3	- AES Ref in	11	GND AES Ref in
4	+ AES OUT 2	12	- AES OUT 2
5	GND OUT 2	13	+ AES OUT 1
6	- AES OUT 1	14	GND OUT 1
7		15	
8			

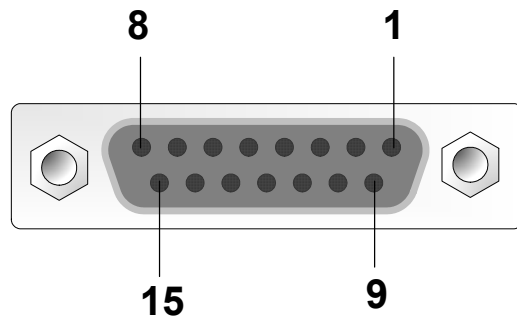

Figure 4 – Audio input connection detail

## Audio Input Connections (un-balanced)

Although the module is designed primarily for balanced line audio connections it is possible to make un-balanced audio connections to the module. **NOTE.** When used in this manor certain technical specifications of the module cannot be maintained.

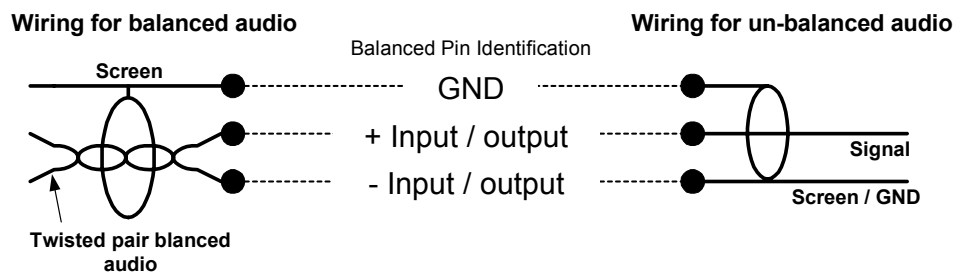

Figure 5 – Audio wiring detail

# Installation



## Caution

The CardModule is shipped in a protective anti-static bag. Please take suitable precautions to avoid static discharge onto any part of the PCB or components when handling module or serious damage could result.

Each Card Module is supplied with a rear connection panel and two mounting screws. Please follow the following procedure for installation of the card module into the Series 5000 Card Frame.

- a) Select a slot in the card frame where the CardModule will be located
- b) Remove the blank connection panel from the rear of the rack (if fitted)
- c) Install the rear connection panel using the screws supplied. Do not tighten the screws fully
- d) Slide the card module into the card frame and carefully check the CardModule easily connects to the rear connection plate. The card should fit easily and should not require excessive force to insert, if you feel any resistance, there could be something wrong with the rear connection panel location. Do not try and force the connection. Remove the rear connection panel and check alignment with the CardModule.
- e) Insert and remove the CardModule a few times to ensure correct alignment and then tighten the two screws to secure the rear connection plate

# Settings and Control

The C AD 5320 has an integrated micro-controller, which enables the module to be configured and controlled locally using the multifunction switch and 4 character dot matrix display, or from remote when using one of the optional controllers and control software.

Once set, all settings are automatically saved in non-volatile internal memory. (Flash ram) The module will always recall the settings used prior to power down.

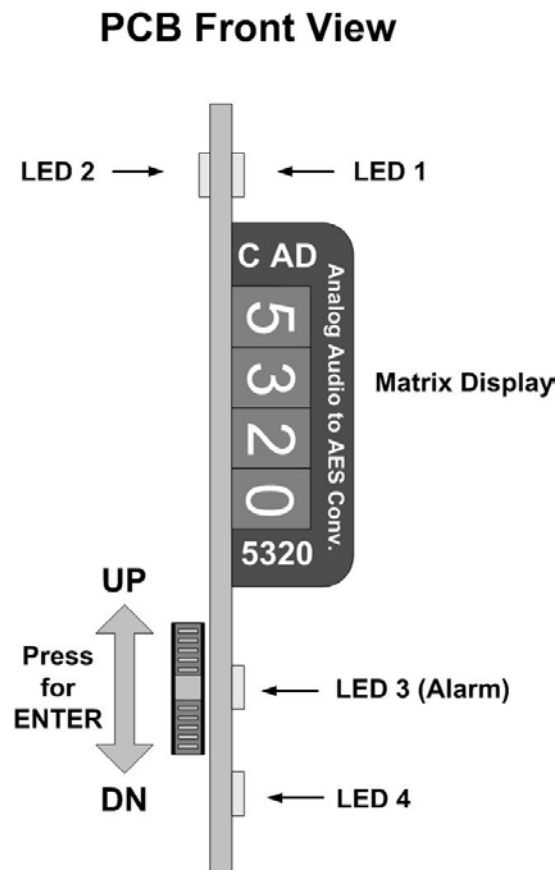
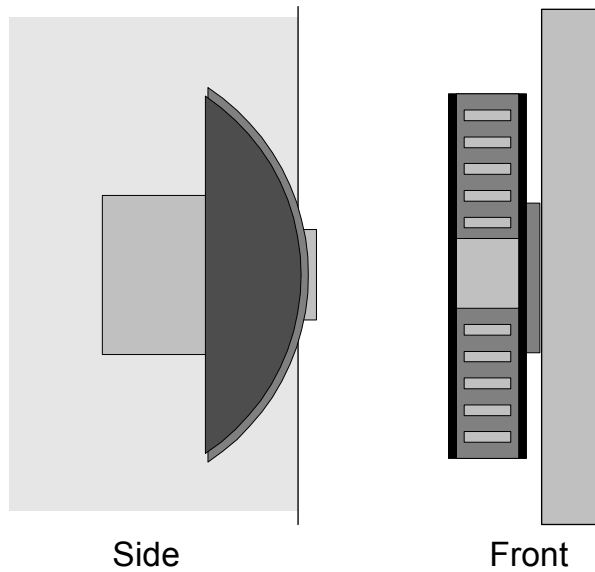

Figure 6 – Switch and Display Location

## Multi Function Switch

The CardModule is equipped with a multi-function switch located on the front bottom edge of the card (refer to figure 6)

### Multi-function Switch



### Switch Operations

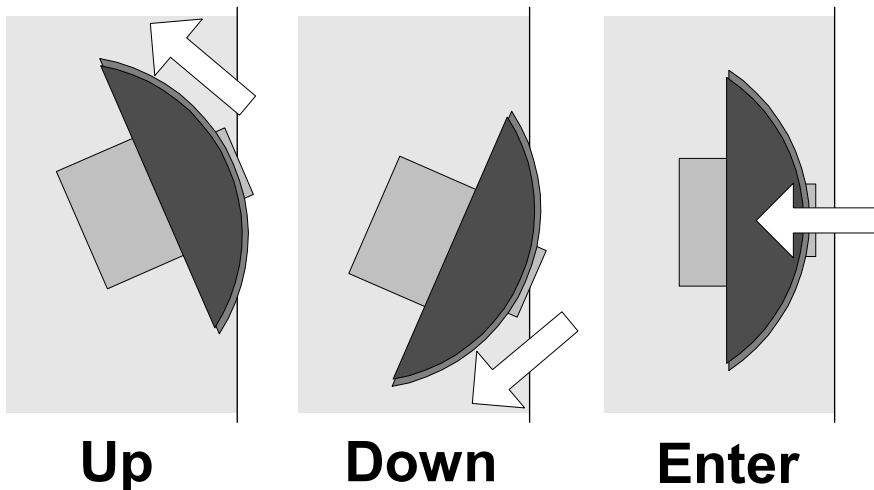

Figure 7 – Switch Operation

## Using the Local Display Menus

Making local adjustments to the module is done using the multifunction switch and the integrated 4-character dot matrix display (figure 3). The menu system is layered, and navigation through the system is done using the **UP** and **DOWN** functions of the switch. **ENTER** is used to move between menu levels and also enter a selection.

### Navigation

Switch Function	Operation
UP	Move UP within a level
DOWN	Move down within a level
ENTER	Change levels / Make selection

### Local Adjustments Available

All of the critical adjustments to the module are accessible using the local display and multi-function switch.

### Factory Default Values

The module can be reset via the local menu to factory preset values:

- Mute off
- 0 dB Full Scale at 15 dBu
- Reference: Video
- Sampling Frequency: 48kHz
- Test Tone off
- Gain: 0 dB = 128

## Menu Structure

The Menu structure is defined in the next table, and should be used when navigating through the system.

### Notes / Tips.

**ENTER** moves between Levels

**UP/DOWN** moves between items within the level

When you enter a new setting the system will jump back one level in the menu system.

The “back” selection in the menu structure will take you back one level when selected.

When an item is selected which has several setting possibilities the first value displayed will be the value currently stored in the system. The order of the available settings for any menu item in the table supplied does not represent the order the settings will actually be displayed.

If left unattended, the menu will default to the root display after a preset timeout.

### Auto Store

If no parameters are changed for 10 seconds then the current settings will be written into flash memory automatically, this can be seen by the alarm LED flashing yellow four times.



ROOT	LEVEL 1	LEVEL 2	LEVEL 3	LEVEL 4	COMMENTS
5320	IN	IN1	MUTE	OFF ON back	"Normal" Root display on module = Module type
		IN2	MUTE	OFF ON back	MUTE Input 1
		FSLV	12dB 15dB 18dB 21dB 24dB back		MUTE Input 2
		back			0 dB Full Scale selection

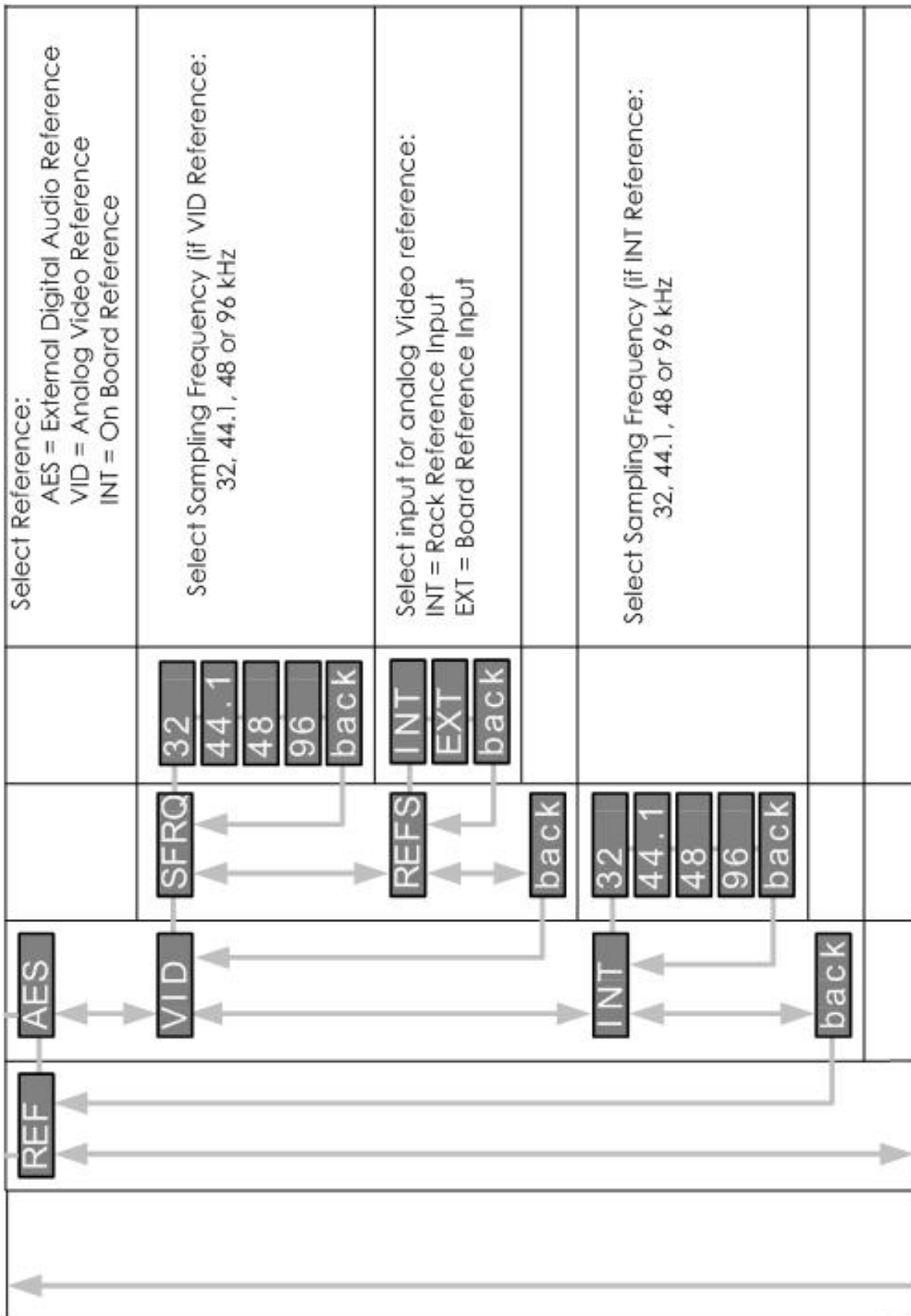

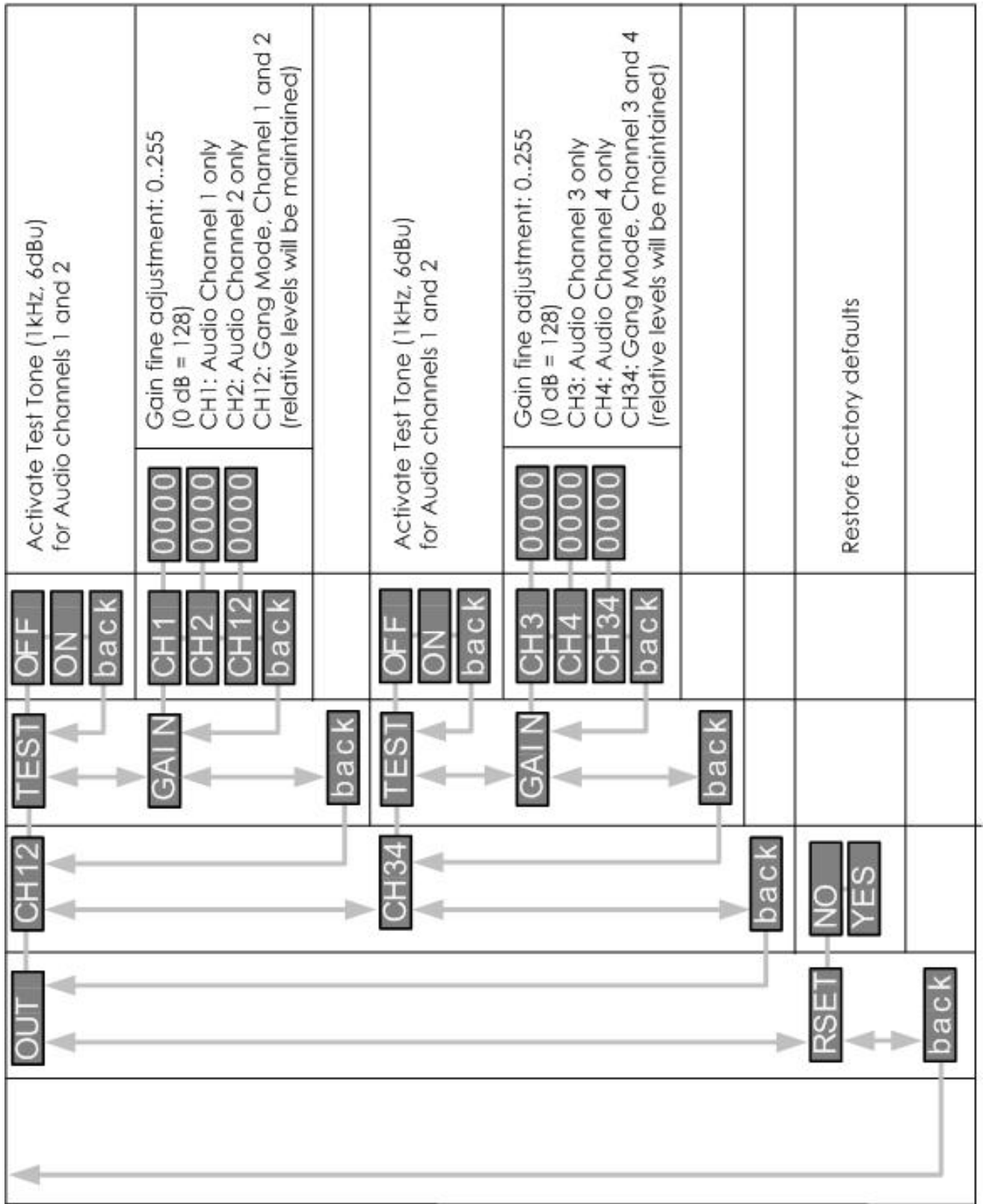

# Alarm/LED Status Indicators

The C AD 5320 module has integral LED indicators, which serve as alarm and status indication for the module. Function is described below.

## Channel Condition Indicators

One LED is provided for each channel

**LED 1** = Channel 1/2

**LED 2** = Channel 3/4

LED State	Indication
Green	Inputs OK and Reference OK, no MUTE, no OVERLOAD
Green Flashing	Inputs OK and Reference OK, but MUTE or OVERLOAD
Yellow	Only one input present, Reference OK, no MUTE, no OVERLOAD or Test tone active
Yellow Flashing	Only one input present and OVERLOAD or MUTE
Red	Inputs missing

## Reference Status Indicator

LED State	Indication
Green	Reference OK (AES or Video Reference)
Yellow	Internal reference
Red	Invalid reference

## Alarm Indicator

There is also a single alarm LED on the lower edge of the module (LED 3). This is visible through the card frame front cover and provides a general indication of the module status.

LED Color	Indication
Green	Inputs and reference OK
Yellow	Test tone selected or one input lost or OVERLOAD or MUTE
Red	No input present

LED **OFF** indicates power is lost, or there is a power supply fault.

## Locate Function

For larger systems which may have multiple cards of the same type in a single rack, or multiple rack systems on a large central control system we have added a useful utility which will help to visually locate a suspect module quickly (When used in conjunction with the optional control system and software)

Once the specific module has been selected on the control system there is a locate button on the top of the GUI:



Locate Function in Control System

When Locate is selected the status indicator on the GUI and the alarm LED will flash yellow in the following continuous sequence.

**3 short flashes.... Pause.... 3 short flashes ...**

Use of the locate function will not interfere with the normal operation of the module.

For more details on this feature please check the documentation supplied with the controller software.

# Specifications *(C AD 5320 D)*

## Analog Input

Signal	2x balanced analog stereo inputs (one stereo signal per channel)
Impedance	110 Ohm
Connection	Female SubD 25pin connector
Max level	24dBu
0dB FS level	Adjustable (12dBu, 15dBu, 18dBu; 21dBu or 24 dBu)

## Reference Input

Video Reference	Black burst, 75Ohm on BNC connector
AES Reference	AES reference input (on SubD 15 pin connector)

## Outputs

Signal	2 x balanced AES3 through isolation transformers
Impedance	110Ohm
Connection	Female SubD 15pin connector
Level	4 V p-p nom.

## Performance

Sampling	Sampling rates: 32kHz, 44.1kHz, 48kHz, 96kHz
Quantization	24 bit
Noise floor	< -100dB (A-weighted, 1kHz, 6dBu)
Distortion	< 0.005% @ 20Hz to 20kHz
Frequency response	+/-0.2dB @ 20Hz to 20kHz
Crosstalk	< -95dB @ 20Hz to 20kHz
Status Monitoring	Signal presence detection Overload detection

## Electrical Specifications

Operating Voltage	+ 12VDC
Power Consumption	5 VA
Safety	IEC 950/ EN 60950/VDE 0805

## Mechanical

Size	283mm x 78 mm
Weight	Card module 120 g, connection panel 50 g

## Ambient

Temperature	5°C to 40°C Maintaining specifications
Humidity	Max 80% non condensing

## Supplied Accessories

Documentation	C AD 5320 D Reference Manual
---------------	------------------------------

## Available Options

Below is a list of related products for the C AD 5320 CardModule. Please refer to product brochures or our web site for more detailed information.

Model	Description
R FR 5010	Series 5000 Rack Frame (empty) with single power supply
R PS 5010	Redundant power supply for the R FR 5010 Card Frame
R CT 5020	Rack controller for the R FR 5010 Card Frame
R CT 5010	Rack Bus Extension for the R FR 5010 Card Frame. In combination with R CT 5020

## Parts List

Due to the very dense design and miniature surface mount technology the module is not field serviceable. The information for a replacement assembly is below.

### **C AD 5320 D CardModule (complete)**

Description	Dual Analog Audio to AES Conv.
Model Number	C AD 5320 D
Part Number	6.155.009.290

### **Sub Assemblies:**

#### **C AD 5320 Processing Board only (BS 5025)**

Part Number	6.155.001.252
-------------	---------------

#### **Rear Connection Panel for C AD 5320 D (MA5002\_A)**

Part Number	6.155.007.262
-------------	---------------

# Service

If you are experiencing problems, or have questions concerning your C AD 5320 CardModule please contact your local distributor for assistance.

We offer a fixed cost service exchange program for defective Series 5000 CardModules out of Warranty. Please contact your distributor or check our web site for details on this program.

More detailed information and product updates may be available on our web site:

**[www.lynx-technik.com](http://www.lynx-technik.com)**

You will also find links to contact us directly for assistance.



## Contact Information

Please contact your local distributor; this is your local and fastest method for obtaining support and sales information.

LYNX Technik can be contacted directly using the information below.

**Address** LYNX Technik AG  
Brunnenweg 3  
D-64331 Weiterstadt  
Germany.

**Website** [www.lynx-technik.com](http://www.lynx-technik.com)

**E-Mail** [info@lynx-technik.com](mailto:info@lynx-technik.com)

LYNX Technik manufactures a complete range of high quality modular products for broadcast and Professional markets, please contact your local representative or visit our web site for more product information.



*This page is intentionally left blank*

