



Version 1.1

# Reference Manual

## D VD 5020

### Dual SDI Distribution Amplifier

Series 5000  
**CardModule**

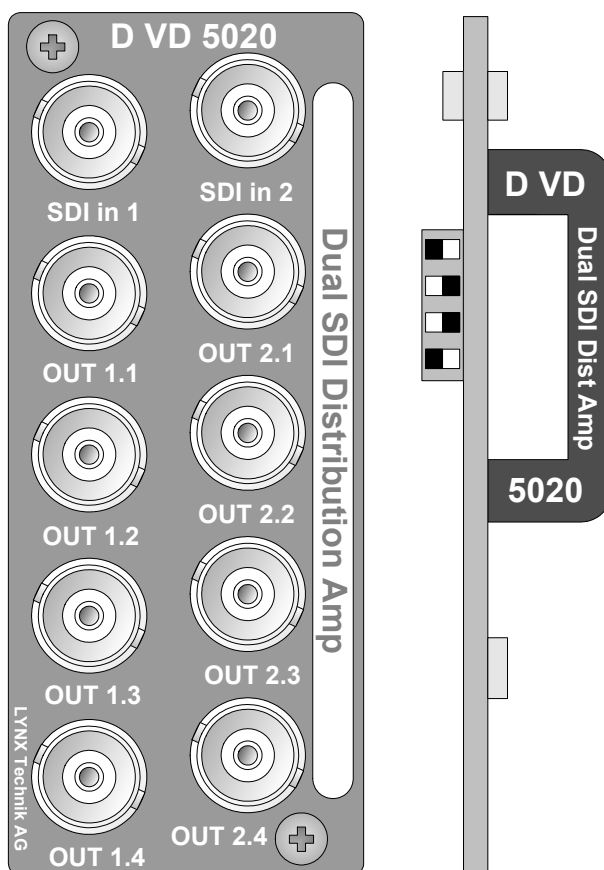

© LYNX Technik AG  
Brunnenweg 3  
D-64331 Weiterstadt  
Germany  
[www.lynx-technik.com](http://www.lynx-technik.com)

Information in this document is subject to change without notice. No part of this document may be reproduced or transmitted in any form or by any means, electronic or mechanical for any purpose, without express written permission of LYNX Technik AG.

LYNX Technik AG may have patents, patent applications, trademarks, copyrights or other intellectual property rights covering the subject matter in this document. Except as expressly written by LYNX Technik AG, the furnishing of this document does not give you any license to patents, trademarks, copyrights or other intellectual property of LYNX Technik AG or any of its affiliates.

© LYNX Technik AG 2002 all rights reserved

# Warranty

LYNX Technik AG warrants that the product will be free from defects in materials and workmanship for a period of two (2) year from the date of shipment. If this product proves defective during the warranty period, LYNX Technik AG at its option will either repair the defective product without charge for parts and labor, or will provide a replacement in exchange for the defective product.

In order to obtain service under this warranty, customer must notify LYNX Technik of the defect before expiration of the warranty period and make suitable arrangements for the performance of service. Customer shall be responsible for packaging and shipping the defective product to the service center designated by LYNX Technik, with shipping charges prepaid. LYNX Technik shall pay for the return of the product to the customer if the shipment is within the country which the LYNX Technik service center is located. Customer shall be responsible for payment of all shipping charges, duties, taxes and any other charges for products returned to any other locations.

This warranty shall not apply to any defect, failure, or damage caused by improper use or improper or inadequate maintenance and care. LYNX Technik shall not be obligated to furnish service under this warranty a) to repair damage resulting from attempts by personnel other than LYNX Technik representatives to install, repair or service the product; b) to repair damage resulting from improper use or connection to incompatible equipment; c) to repair any damage or malfunction caused by the use of non LYNX Technik supplies; or d) to service a product which has been modified or integrated with other products when the effect of such modification or integration increases the time or difficulty servicing the product.

**THIS WARRANTY IS GIVEN BY LYNX TECHNIK WITH RESPECT TO THIS PRODUCT IN LIEU OF ANY OTHER WARRANTIES, EXPRESS OR IMPLIED. LYNX TECHNIK AND ITS VENDORS DISCLAIM ANY IMPLIED WARRANTIES OF MERCHANTABILITY OR FITNESS FOR A PARTICULAR PURPOSE. LYNX TECHNIK`S RESPONSIBILITY TO REPAIR AND REPLACE DEFECTIVE PRODUCTS IS THE SOLE AND EXCLUSIVE REMEDY PROVIDED TO THE CUSTOMER FOR BREACH OF THIS WARRANTY. LYNX TECHNIK AND ITS VENDORS WILL NOT BE LIABLE FOR ANY INDIRECT, SPECIAL, INCIDENTAL, OR CONSEQUENTIAL DAMAGES IRRESPECTIVE OF WHETHER LYNX TECHNIK OR THE VENDOR HAS ADVANCE NOTICE OF THE POSSIBILITY OF SUCH DAMAGES.**

# Regulatory information

## Europe

### Declaration of Conformity

We	LYNX Technik AG Brunneweg 3 D-64331 Weiterstadt Germany
<i>Declare under our sole responsibility that the product</i>	
TYPE: D VD 5020	
<i>To which this declaration relates is in conformity with the following standards (environments E1-E3):</i>	
EN 55103-1 /1996	
EN 55103-2 /1996	
EN 60950 /2001	
<i>Following the provisions of 89/336/EEC and 73/23/EEC directives.</i>	
	Winfried Deckelmann
Weiterstadt, June 2003	
<i>Place and date of issue</i>	<i>Legal Signature</i>

## USA

### FCC 47 Part 15

This device complies with part 15 of the FCC Rules. Operation is subject to the following two conditions: (1) This device may not cause harmful interference, and (2) this device must accept any interference received, including interference that may cause undesired operation.

Note: This equipment has been tested and found to comply with the limits for a Class A digital device, pursuant to the part 15 of the FCC Rules. These limits are designed to provide reasonable protection against harmful interference when the equipment is operated in a commercial environment. This equipment generates, uses, and can radiate radio frequency energy and, if not installed and used in accordance with the instruction manual, may cause harmful interference to radio communications. Operation of this equipment in a residential area is likely to cause harmful interference in which case the user will be required to correct the interference at his own expense

---

# Contents

<b>Warranty</b> .....	<b>3</b>
<b>Regulatory information</b> .....	<b>4</b>
Europe.....	4
Declaration of Conformity .....	4
USA .....	4
FCC 47 Part 15.....	4
<b>Contents</b> .....	<b>5</b>
<b>Getting Started</b> .....	<b>7</b>
Packaging.....	7
Product Description .....	7
Functional Diagram .....	8
Module Layout .....	8
<b>Connections</b> .....	<b>10</b>
Video Connections.....	10
<b>Installation</b> .....	<b>11</b>
<b>Settings and Control</b> .....	<b>12</b>
Switch Settings .....	13
Switch Function Detail .....	13
Factory Preset Condition.....	14
Auto Store .....	14
<b>Alarm/LED Status Indicators</b> .....	<b>15</b>
Channel Condition Indicators .....	15
Alarm Indicator .....	15
Locate Function.....	16
<b>Specifications (D VD 5020)</b> .....	<b>17</b>
<b>Available Options</b> .....	<b>18</b>
<b>Parts List</b> .....	<b>18</b>
<b>Service</b> .....	<b>19</b>
<b>Contact Information</b> .....	<b>20</b>

*This page is intentionally left blank*

# Getting Started

## Packaging

The shipping carton and packaging materials provide protection for the module during transit. Please retain the shipping cartons in case subsequent shipping of the product becomes necessary.

## Product Description

The D VD 5020 is a high quality digital video distribution amplifier designed primarily for broadcast and professional applications.

Flexible configurations allow the D VD 5020 to be used in dual 1 to 4 applications or 1 to 8 applications. Outputs can be reclocked, or non-reclocked and even split between reclocked and non-reclocked outputs within the same module. Auto detection of standard digital video bit rates in reclocked mode (143Mbit/s, 177Mbit/s, 270Mbit/s, 360Mbit/s, 540Mbit/s) and will transparently pass data from 10Mbits/s to 640Mbits/s in non-reclocked mode.

The D VD 5020 is part of the 5000 series of CardModules, which offer high quality, modularity and flexibility in a small form factor ideal for applications where space is at a premium.

CardModules are installed in the series 5000 card frame that can accommodate up to 10 CardModules. All modules are hot swappable and Options include full redundant power and a range of controller options.

# Functional Diagram

Figure 1 below is the basic functional diagram for the D VD 5020 CardModule.

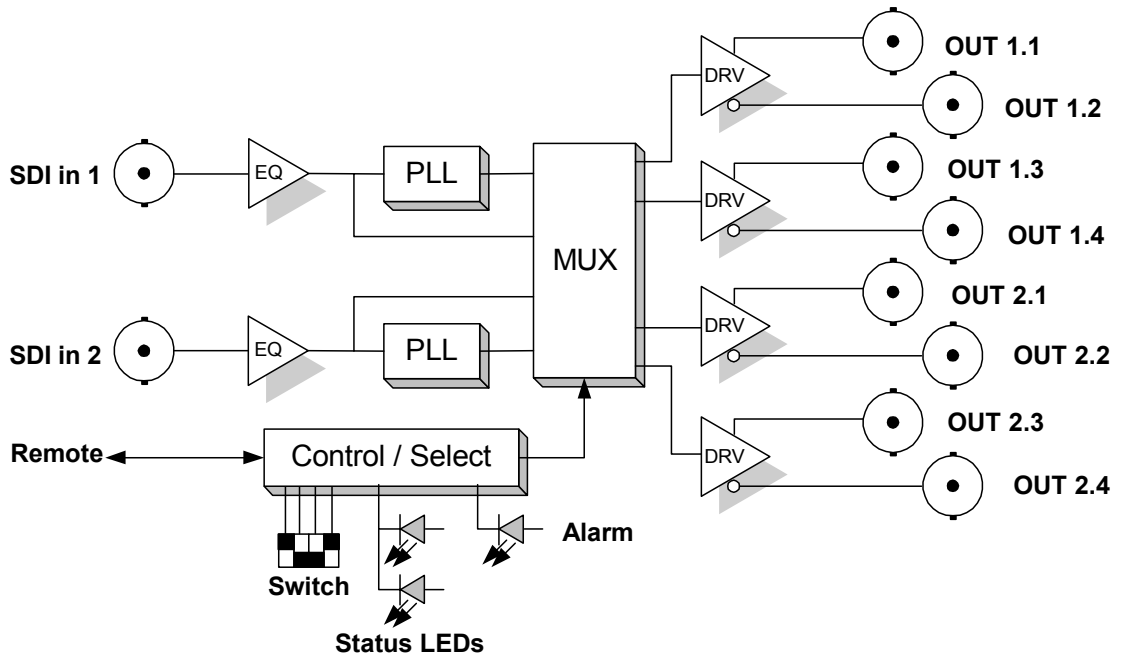

Figure 1- D VD 5020 Functional Diagram

# Module Layout

Figure 2 shows the layout of the D VD 5020 CardModule and the rear connection panel. Please refer the connections section of this manual for wiring details for the connectors.



**PCB Layout**

**Rear Connection Panel**

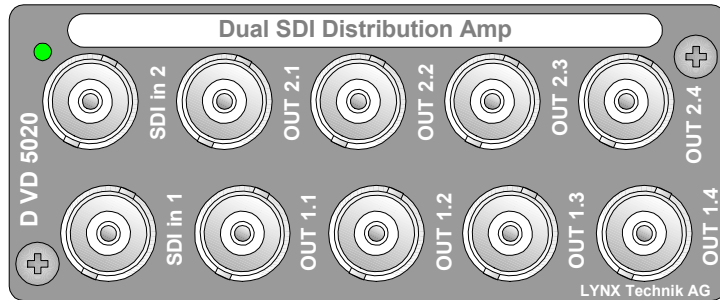
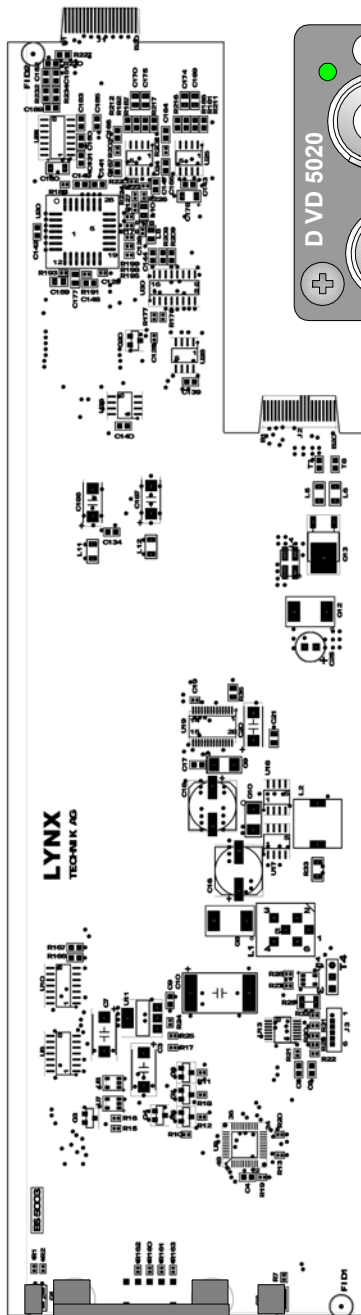

**PCB Front View**

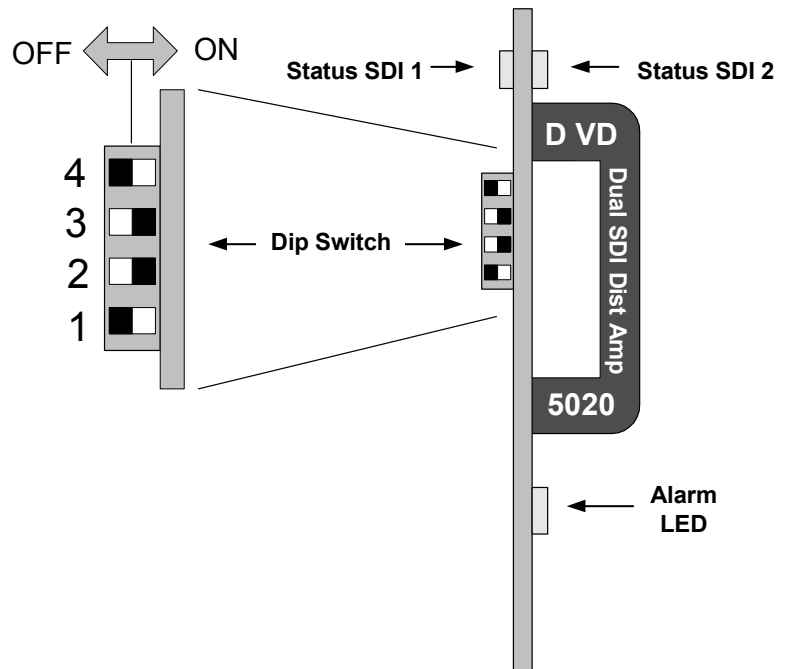

Figure 2 – Module Layout



**Caution**

Use static precautions when handling the PCB. Static discharge could result in serious damage to the module.

# Connections

## Video Connections

The D VD 5020 CardModule is configured with standard 75 Ohm BNC connectors. Connection is self-explanatory. We recommend the use of high quality video cable for digital video connections to reduce the risk of interference or errors due to excessive cable attenuation. Some guidelines for max cable length are shown below.

250m (820 feet) Belden 8281 (270Mbits/s)

150m (492 feet) Belden 8281 (540Mbits/s)

**Note.** Due to the compact design of the connection plate it will be necessary to use a connection tool to secure the BNC video connectors.

# Installation



## Caution

The CardModule is shipped in a protective anti-static bag. Please take suitable precautions to avoid static discharge onto any part of the PCB or components when handling module or serious damage could result.

Each Card Module is supplied with a rear connection panel and two mounting screws. Please follow the following procedure for installation of the card module into the Series 5000 Card Frame.

- a) Select a slot in the card frame where the CardModule will be located
- b) Remove the blank connection panel from the rear of the rack (if fitted)
- c) Install the rear connection panel using the screws supplied. Do not tighten the screws fully
- d) Slide the card module into the card frame and carefully check the CardModule easily connects to the rear connection plate. The card should fit easily and should not require excessive force to insert, if you feel any resistance, there could be something wrong with the rear connection panel location. Do not try and force the connection. Remove the rear connection panel and check alignment with the CardModule.
- e) Insert and remove the CardModule a few times to ensure correct alignment and then tighten the two screws to secure the rear connection plate

# Settings and Control

The D AA 5020 has an integrated micro-controller, which enables the module to be configured and controlled locally via the dip-switch or from remote when using one of the optional controllers and control software.

Once set, all settings are automatically saved in non-volatile internal memory. (Flash ram) The module will always recall the settings used prior to power down.

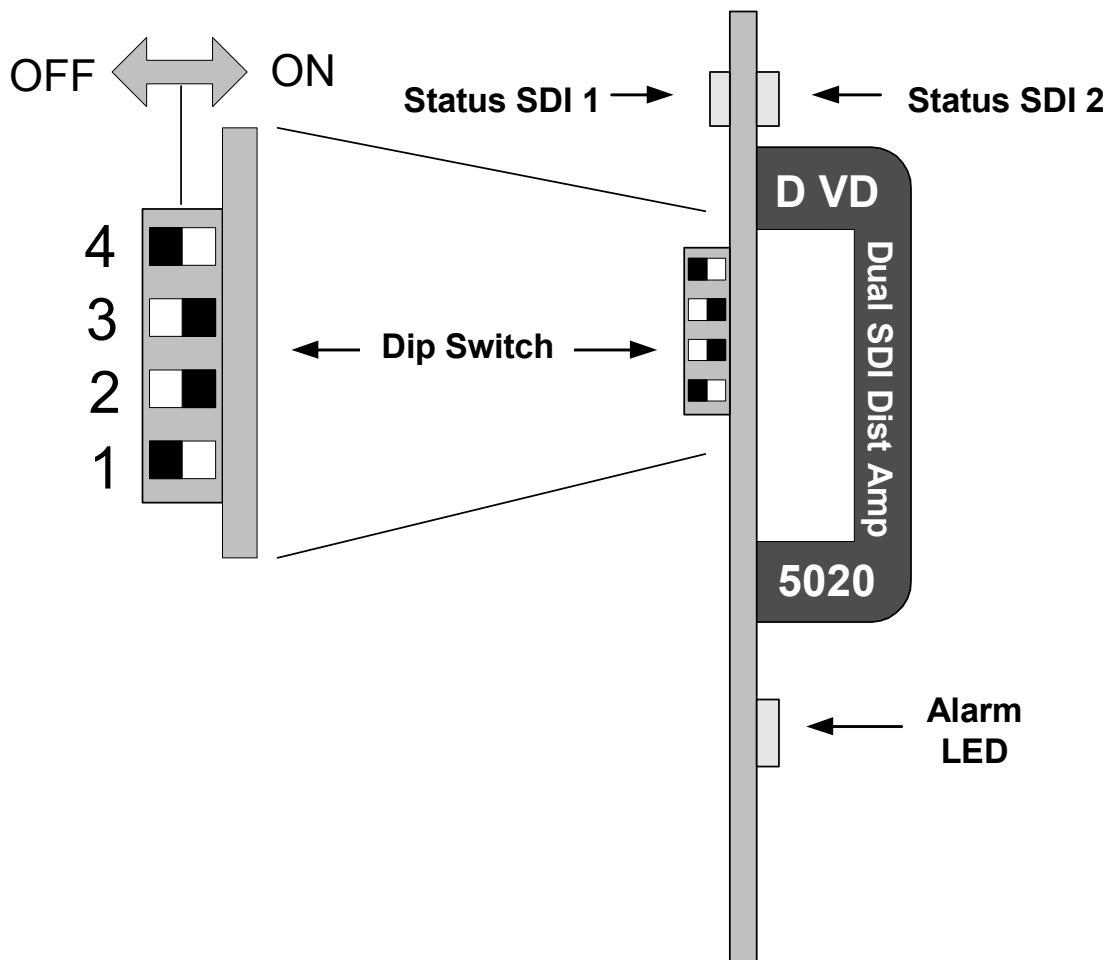

Figure 3 – Switch and LED locations

## Switch Settings

Below the switch settings for the 4-position dip-switch are defined.

Switch	Setting	Function
1	ON	Enable Local Adjustment
	OFF	Disable Local Adjustment
2	ON	Dual 1:4 mode
	OFF	Single 1:8 mode *
3	ON	Outputs 1 to 4 Reclocked
	OFF	Outputs 1 to 4 Non-reclocked
4	ON	Outputs 5 to 8 Reclocked
	OFF	Outputs 5 to 8 Non-reclocked

\*When in single mode the **IN 2** video input is used

### Switch Function Detail

#### Dip Switch 1

This switch is used to enable or disable local adjustments. Set to **ON** enables the setting of the other dip switches to configure the module. Set to **OFF** will prevent any switch settings taking effect.

**Note.** The module has a microcontroller and flash ram. When this switch 1 is set to **ON** any configuration settings made on the module with the dip switches will automatically be written into flash ram and stored. (see Auto Store) The module will function normally with the switch left in the **ON** position but it is recommended to set it to **OFF** to prevent accidental changes to the stored module configuration if the switches are moved.

#### Dip Switch 2

When set to **ON** this configures the module for dual 1:4 mode of operation, **OFF** sets single 1:8 mode.

**Note** when in 1:8 mode **IN 2** is used for the single input channel.

### **Dip Switch 3**

This switch configures outputs 1 to 4 to be reclocked or non reclocked. **ON** sets reclocked **OFF** sets non-reclocked

### **Dip Switch 4**

This switch configures outputs 5 to 8 to be reclocked or non reclocked. **ON** sets reclocked **OFF** sets non-reclocked

## **Factory Preset Condition**

The D VD 5020 is delivered programmed and preset for the following mode of operation:

Switch 1 **OFF** Local Adjustment Disabled  
Switch 2 **ON** Dual 1 > 4 mode  
Switch 3 **ON** Channel 1 reclocked  
Switch 4 **ON** Channel 2 reclocked

If this is the mode of operation required, then no adjustments are necessary.

## **Auto Store**

If no parameters are changed for 10 seconds then the current settings will be written into flash memory automatically, this can be seen by the channel status LEDs flashing yellow four times.

# Alarm/LED Status Indicators

The D VD 5020 module has integral LED indicators, which serve as alarm and status indication for the module. Function is described below.

## Channel Condition Indicators

2 status LEDs are provided on the top edge of the module, one for each channel (figure 3)

LED Color	Indication
Green	Input Present
Yellow	Input detected, PLL not locked
Red	Input Lost

## Alarm Indicator

There is also a single alarm LED on the lower edge of the module (figure 3). This is visible through the card frame front cover and provides a general indication of the module status.

LED Color	Indication
Green	Signal Present (locked)
Yellow	When in dual mode (2 x 1:4) this indicates only one input signal is present
Red	Input signal lost

LED **OFF** indicates power is lost, or there is a power supply fault.

## Locate Function

For larger systems which may have multiple cards of the same type in a single rack, or multiple rack systems on a large central control system we have added a useful utility which will help to visually locate a suspect module quickly (When used in conjunction with the optional control system and software)

Once the specific module has been selected on the control system there is a locate button on the top of the GUI:

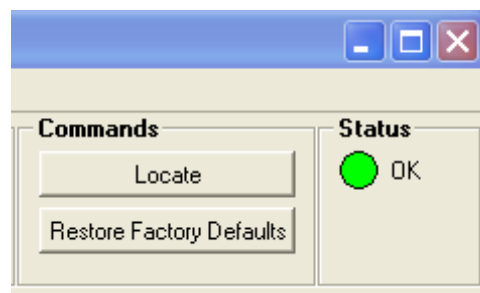

Locate Function in Control System

When Locate is selected the status indicator on the GUI and the alarm LED will flash yellow in the following continuous sequence.

### **3 short flashes.... Pause.... 3 short flashes ...**

Use of the locate function will not interfere with the normal operation of the module.

For more details on this feature please check the documentation supplied with the controller software.



# Specifications (D VD 5020)

## Inputs

Signal	1 or 2 Serial Digital Video. SMPTE 259M-C
Input Impedance	75 Ohms
Input level	0.8V p-p
Return loss	> 15dB (270MHz)
Connection	BNC

## Outputs

Signal	8 Serial Digital Video. SMPTE 259M-C
Output Impedance	75 Ohms
Output Level	0.8V p-p nom.
Return loss	> 15dB (270 Mbit/s)
Connection	BNC

## Operating Modes

Dual	2 x 1:4 (reclocked or non clocked)
Single	1 x 1:8 (reclocked or non clocked)

## Performance

Cable Equalization	Up to 250m using Belden 8281 (270Mbit/s)
Jitter	< 0.2 UI
Control	Local settings (dip switch).
Status Monitoring (LED)	Signal presence and PLL lock indication

## Electrical Specifications

Operating Voltage	+ 5VDC
Power Consumption	3.5 W
Safety	IEC 60950/ EN 60950/VDE 0805

## Mechanical

Size	283mm x 78mm
Weight	Card module 120g, connection panel 50g

## Ambient

Temperature	5°C to 40°C Maintaining specifications
Humidity	Max 90% non condensing

## Supplied Accessories

Documentation	D VD 5020 Reference Manual
---------------	----------------------------

## Available Options

Below is a list of related products for the D VD 5020 CardModule. Please refer to product brochures or our web site for more detailed information.

Model	Description
R FR 5010	Series 5000 Rack Frame (empty) with single power supply
R PS 5010	Redundant power supply for the R FR 5010 Card Frame
R CT 5020	Rack controller for the R FR 5010 Card Frame
R CT 5010	Rack Bus Extension for the R FR 5010 Card Frame. In combination with R CT 5020

## Parts List

Due to the very dense design and miniature surface mount technology the module is not field serviceable. The information for a replacement assembly is below.

### **D VD 5020 CardModule (complete)**

Description	Dual SDI Distribution Amplifier
Model Number	D VD 5020
Part Number	6.155.008.230

### **Sub Assemblies:**

#### **D VD 5020 Processing Board only. (BS 5003)**

Part Number	6.155.004.291
-------------	---------------

#### **Rear Connection Panel for D VD 5020 (MA5001\_B)**

Part Number	6.155.008.371
-------------	---------------

# Service

If you are experiencing problems, or have questions concerning your D VD 5020 CardModule please contact your local distributor for assistance.

We offer a fixed cost service exchange program for defective Series 5000 CardModules out of Warranty. Please contact your distributor or check our web site for details on this program.

More detailed information and product updates may be available on our web site:

**[www.lynx-technik.com](http://www.lynx-technik.com)**

You will also find links to contact us directly for assistance.

## Contact Information

Please contact your local distributor; this is your local and fastest method for obtaining support and sales information.

LYNX Technik can be contacted directly using the information below.

**Address** LYNX Technik AG  
Brunnenweg 3  
D-64331 Weiterstadt  
Germany.

**Website** [www.lynx-technik.com](http://www.lynx-technik.com)

**E-Mail** [info@lynx-technik.com](mailto:info@lynx-technik.com)

LYNX Technik manufactures a complete range of high quality modular products for broadcast and Professional markets, please contact your local representative or visit our web site for more product information.



