



Reference Manual

V 3.0

C DA 3002

Dual SDI to Analog Video Converter

Series 3000
MiniModules

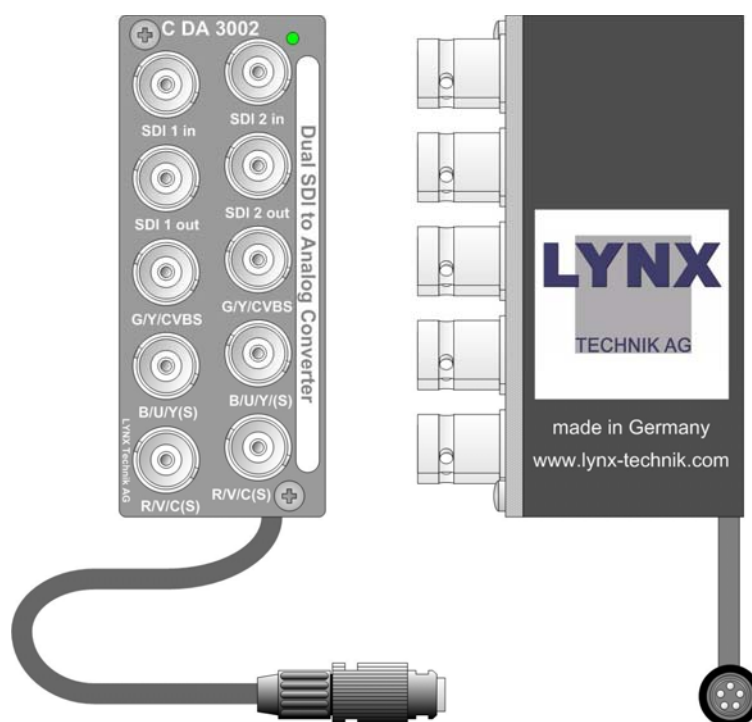

© LYNX Technik AG
Brunnenweg 3
64331 Weizterstadt
Germany
www.lynx-technik.com

Information in this document is subject to change without notice. No part of this document may be reproduced or transmitted in any form or by any means, electronic or mechanical for any purpose, without express written permission of LYNX Technik AG.

LYNX Technik AG may have patents, patent applications, trademarks, copyrights or other intellectual property rights covering the subject matter in this document. Except as expressly written by LYNX Technik AG, the furnishing of this document does not give you any license to patents, trademarks, copyrights or other intellectual property of LYNX Technik AG or any of its affiliates.

© LYNX Technik AG 2006 all rights reserved

Warranty

LYNX Technik AG warrants that the product will be free from defects in materials and workmanship for a period of two (2) years from the date of shipment. If this product proves defective during the warranty period, LYNX Technik AG at its option will either repair the defective product without charge for parts and labor, or will provide a replacement in exchange for the defective product.

In order to obtain service under this warranty, customer must notify LYNX Technik of the defect before expiration of the warranty period and make suitable arrangements for the performance of service. Customer shall be responsible for packaging and shipping the defective product to the service center designated by LYNX Technik, with shipping charges prepaid. LYNX Technik shall pay for the return of the product to the customer if the shipment is within the country which the LYNX Technik service center is located. Customer shall be responsible for payment of all shipping charges, duties, taxes and any other charges for products returned to any other locations.

This warranty shall not apply to any defect, failure, or damage caused by improper use or improper or inadequate maintenance and care. LYNX Technik shall not be obligated to furnish service under this warranty a) to repair damage resulting from attempts by personnel other than LYNX Technik representatives to install, repair or service the product; b) to repair damage resulting from improper use or connection to incompatible equipment; c) to repair any damage or malfunction caused by the use of non LYNX Technik supplies; or d) to service a product which has been modified or integrated with other products when the effect of such modification or integration increases the time or difficulty servicing the product.

THIS WARRANTY IS GIVEN BY LYNX TECHNIK WITH RESPECT TO THIS PRODUCT IN LIEU OF ANY OTHER WARRANTIES, EXPRESS OR IMPLIED. LYNX TECHNIK AND ITS VENDORS DISCLAIM ANY IMPLIED WARRANTIES OF MERCHANTABILITY OR FITNESS FOR A PARTICULAR PURPOSE. LYNX TECHNIK`S RESPONSIBILITY TO REPAIR AND REPLACE DEFECTIVE PRODUCTS IS THE SOLE AND EXCLUSIVE REMEDY PROVIDED TO THE CUSTOMER FOR BREACH OF THIS WARRANTY. LYNX TECHNIK AND ITS VENDORS WILL NOT BE LIABLE FOR ANY INDIRECT, SPECIAL, INCIDENTAL, OR CONSEQUENTIAL DAMAGES IRRESPECTIVE OF WHETHER LYNX TECHNIK OR THE VENDOR HAS ADVANCE NOTICE OF THE POSSIBILITY OF SUCH DAMAGES.

Regulatory information

Europe

Declaration of Conformity

We	LYNX Technik AG Brunnenweg 3 D-64331 Weiterstadt Germany
<i>Declare under our sole responsibility that the product</i>	
TYPE: C DA 3002	
<i>To which this declaration relates is in conformity with the following standards (environments E1-E3):</i>	
EN 55103-1 /1996	
EN 55103-2 /1996	
EN 60950 /2001	
<i>Following the provisions of 89/336/EEC and 73/23/EEC directives.</i>	
	Winfried Deckelmann
Weiterstadt, October 2006	
<i>Place and date of issue</i>	<i>Legal Signature</i>

USA

FCC 47 Part 15

This device complies with part 15 of the FCC Rules. Operation is subject to the following two conditions: (1) This device may not cause harmful interference, and (2) this device must accept any interference received, including interference that may cause undesired operation.

Note: This equipment has been tested and found to comply with the limits for a Class A digital device, pursuant to the part 15 of the FCC Rules. These limits are designed to provide reasonable protection against harmful interference when the equipment is operated in a commercial environment. This equipment generates, uses, and can radiate radio frequency energy and, if not installed and used in accordance with the instruction manual, may cause harmful interference to radio communications. Operation of this equipment in a residential area is likely to cause harmful interference in which case the user will be required to correct the interference at his own expense

Contents

Warranty	3
Regulatory information.....	4
Europe.....	4
Declaration of Conformity	4
USA	4
FCC 47 Part 15	4
Contents	5
Getting Started.....	7
Packaging.....	7
Product Description	7
Functional Diagram	9
Module Layout	9
Connections.....	11
Video Connections.....	11
Power Connections	12
DC Power Connector	12
Installation	13
Mechanical.....	13
Stand Alone Operation.....	13
Multiple Units	14
Electrical Installation	15
Stand Alone Operation.....	15
Multiple Units	16
Settings and Control	16
Switch Settings	16
Switch Function Detail	17
Factory Preset Condition.....	18
Alarm/LED Status Indicators.....	19
Module Edge Status LED	19
(per channel)	19
Alarm Indicator	19
Locate Function	20
Auto Store	20
Specifications (C DA 3002)	21
Available Options	22
Parts List	23
Service	23
Contact Information	24

This Page is intentionally left blank

Getting Started

Packaging

The shipping carton and packaging materials provide protection for the module during transit. Please retain the shipping cartons in case subsequent shipping of the product becomes necessary.

Product Description

The C DA 3002 is a high quality dual 8 bit video digital to analog converter designed primarily for broadcast and professional applications.

The module has two independent conversion channels and each channel accepts 1 SDI input signal. Each channel has three modes of operation using the shared connections on the front connection panel. GBR, YUV or S-Video and composite (CVBS) outputs. The module provides a re-clocked SDI loop through signal for further use downstream.

The C DA 3002 has a variety of features, which include:

- Two independent D to A conversion channels with separate control
- Component (RGB or YUV) or (S video and composite) output for each channel
- PAL or NTSC operation for each channel
- Internal color bars
- Internal 4x over sampling (54MHz)
- Reclocked SDI loop through output
- Local DIP-switches and LED's for control and status monitoring.
- Microprocessor controlled.
- Flash Ram storage for settings.
- Remote control interface.

The module has a built in micro-controller with local controls, status and alarm indicators and well as internal flash ram for storing setups. Any operational parameters configured and stored into the module are recalled when powered up. Remote control and remote status monitoring is possible when used with the rack frame option and host controller.

The C DA 3002 is part of the 3000 series of MiniModules, which offer high quality, modularity and flexibility in a very small form factor ideal for applications where space is at a premium.

The modules can be used either stand alone using the optional power supply brick, or as part of a tightly integrated space saving system where up to 10 MiniModules can be mounted utilizing the optional LYNX R FR 3005 / 3010 rack housing. This includes integrated power supply and optional remote control interfaces.

Functional Diagram

Figure 1 below is the basic functional diagram for the C DA 3002 MiniModule.

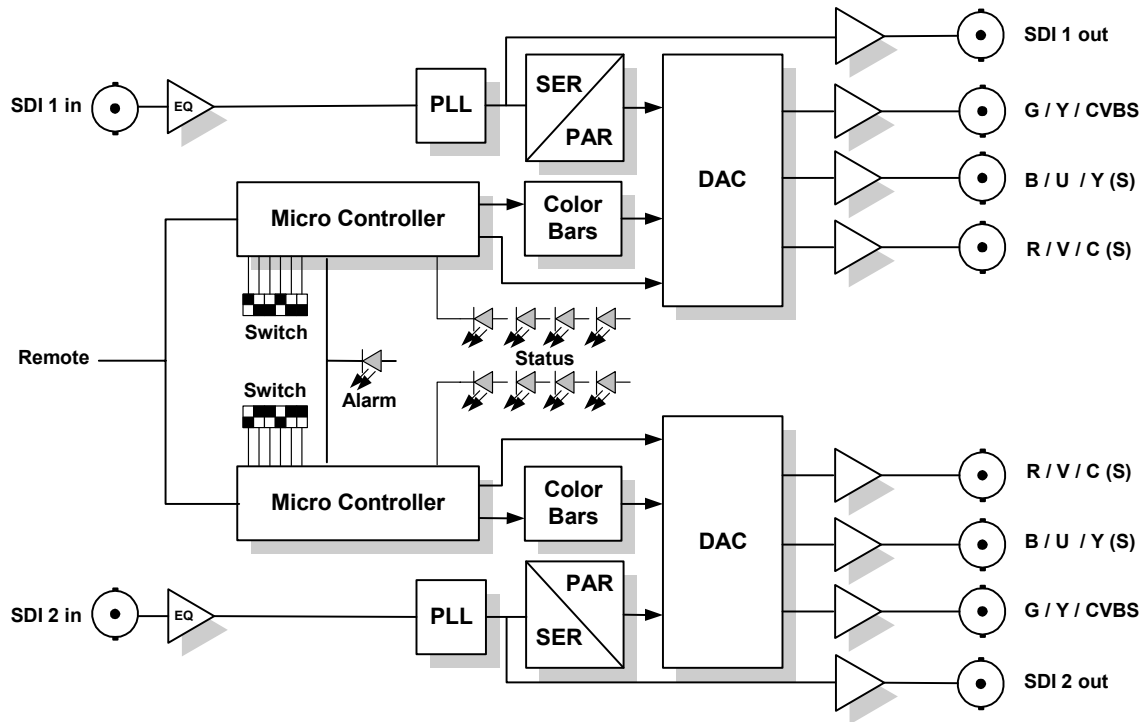

Figure 1- C DA 3002 Functional Diagram

Module Layout

Figure 2 shows the physical layout of the C DA 3002 MiniModule. Video I/O is made through standard 75 Ohm BNC video connections. Module configuration is set via small dip-switches located behind an access hole in the bottom of the module.

If the module is being used in a stand alone application then the optional power supply (R PS 1 E or R PS 1 U) is required to power the module (not shown)

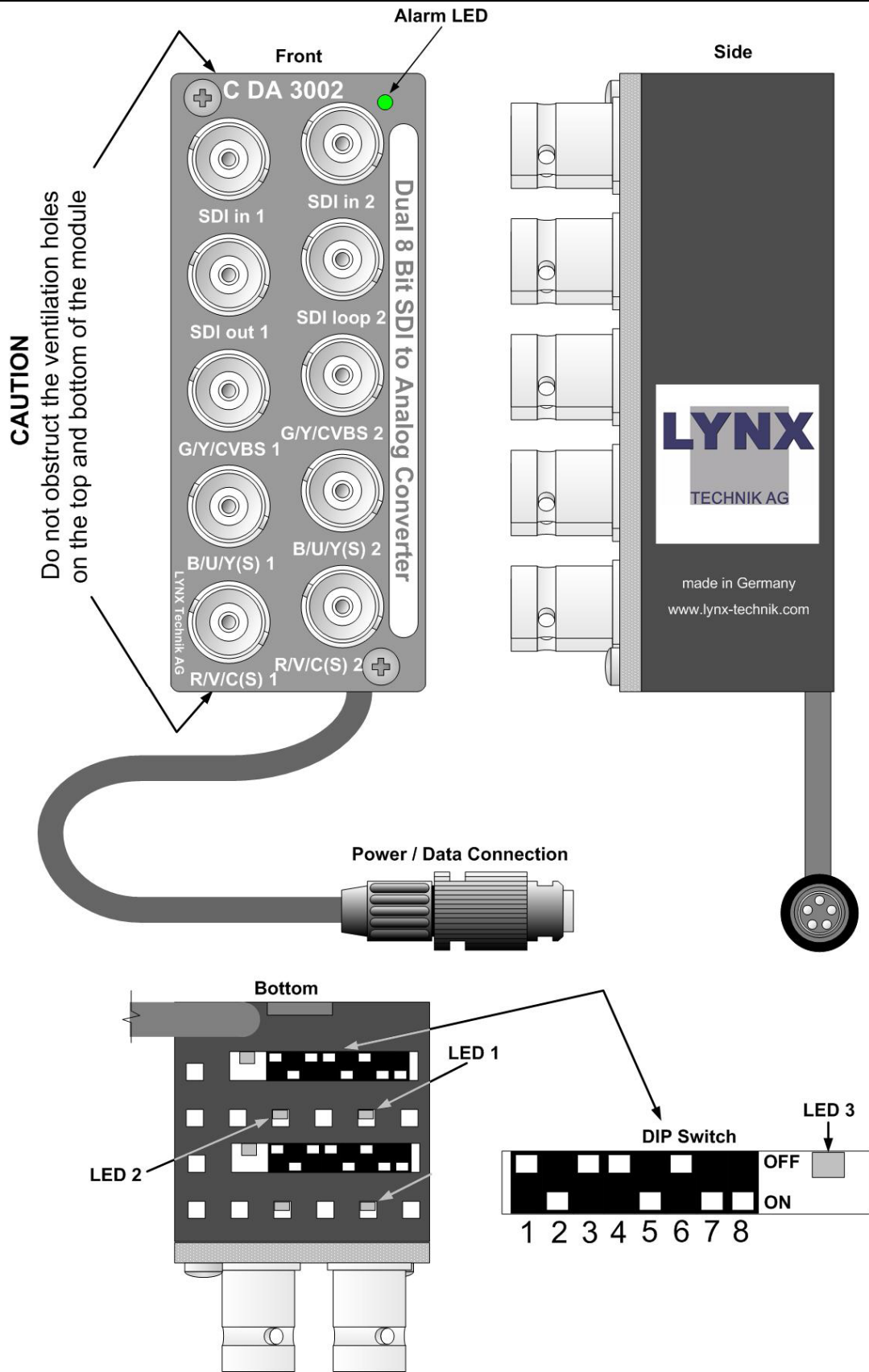

Figure 2 – Module Layout

Connections

Video Connections

The C DA 3002 MiniModule is configured with standard 75 Ohm BNC connectors. Connection is self-explanatory. We recommend the use of high quality video cable suitable for digital video connections to reduce the risk of interference or errors due to excessive cable attenuation.

Note. Due to the compact design of the module it will be necessary to use a connection tool to secure the BNC video connectors to the module.

Power Connections

If using the module in a stand-alone application use the separate R PS 3001 E (for Europe), R PS 3001 U (USA) power brick option, the universal desk power supply R PS 3001-3 or the R PS 3004 desk power supply for 4 MiniModules.

DC Power Connector

The MiniModule has a captive power lead fitted to the module, with a male 5 pin locking bayonet connector. This connection provides DC power and also data connectivity to the module. Connector wiring is shown below.

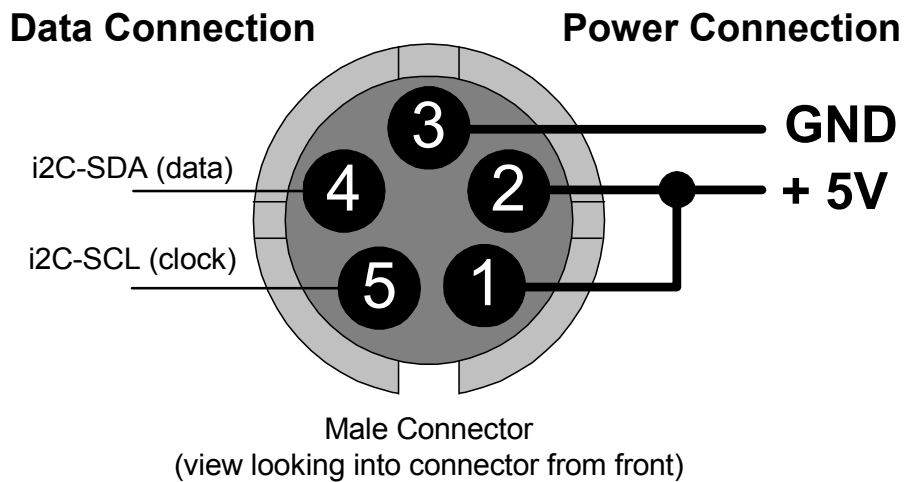

Caution



Only use the optional LYNX R PS power modules. Ensure the 5-pin power connector is locked securely in place.

Installation

Mechanical

Stand Alone Operation

The C DA 3002 MiniModule can be used in a stand alone application. There are two options for the use of the module in this way.

- a) Using the R FR 3005 Rack Frame 1 option. This allows up to any 10 of the MiniModules to be secured onto a rack frame assembly for 19 inch rack mounting. This keeps the modules secured, organized and out of the way. The R PS 3001 power brick option or the R FR 3010 option is required to power each module. Please refer to the R FR 3005 Reference Manual supplied with this option for more details.
- b) Single Use. The MiniModule can be powered independently with one of the R PS 300x options and used in any location where this functionality is required.



Caution. Care needs to be taken when using the module in this way, as it is not physically secured. Keep the module away from the floor to avoid the risk of someone stepping or tripping on the unit, and locate the unit away from excessive sources of heat and any sources or moisture.

If using more than one MiniModule in any installation, the R FR 3005/3010 Rack frame combination is highly recommended.

Multiple Units

Most applications will require more than one MiniModule, which can include any of the available Series 3000 MiniModule product range. There are two options for mounting multiple units.

- a) Using the R FR 3005 Rack Frame option. This allows up to any 10 of the MiniModules to be secured onto a rack frame assembly for 19 inch rack mounting. One of the R PS 300x power brick options or the R FR 3010 option is required to power each module. Please refer to the R FR 3005 Reference Manual for more details.

- b) Using the R FR 3010 Rack frame extension option. Can be combined with the R FR 3005 Rack frame option. Each module plugs into a connection bus, which provides common power for all modules. (no R PS external power supplies are needed). Remote control and status monitoring of all modules is possible with the addition of the R CT 5020 rack controller and R CT 5030 master controller options. Please refer to the respective reference manuals for these options for details of mechanical installation.

The very small size and density of the MiniModules combined with the available rack frame options allows the addition of a complex and custom signal distribution system without taking any additional front rack space. The rack frames are designed for installation in the back of 19-inch racks where there is normally plenty of available space. Ideal for mobile truck installations and facility expansions where space is at a premium.

Electrical Installation.

Stand Alone Operation

The MiniModule requires one of the R PS 300x power brick options for stand-alone operation. Four versions are available; R PS 3001 E for European markets, R PS 3001 U for the US markets, the universal desk power supply R PS 3001-3 or the R PS 3004 desk power supply for 4 MiniModules. Please ensure you have the correct power option for your region. The connection to the module is made with a small 5-pin connector, which has a twist bayonet securing system. Please make sure the connection is solid and locked in place. A strain relief is included within the module to prevent excessive strain on the connection.

Signal connections should be made with care, please ensure connections are correct and compatible equipment is feeding / receiving the signals from the module or damage can result.



Caution. Only use the optional LYNX R PS 300x power modules. Ensure the 5-pin power connector is locked securely in place.



Caution. Care needs to be taken when using the module in this way, if it is not physically secured. Keep the module away from the floor to avoid the risk of someone stepping or tripping on the unit, and locate the unit away from excessive sources of heat and any sources or moisture.

Multiple Units

When installing multiple MiniModule units it is recommended you use the R FR 3005 Rack Frame 1 and / or R FR 3010 Rack Frame 2 options. Please refer to the documentation supplied with these options for details on electrical installation.

Settings and Control

The C DA 3002 is configured via the integral 6-position dip-switches. These are located on the bottom of the module and can be accessed through the cutout provided (fig 2) Both channels are identical and only one is described below.

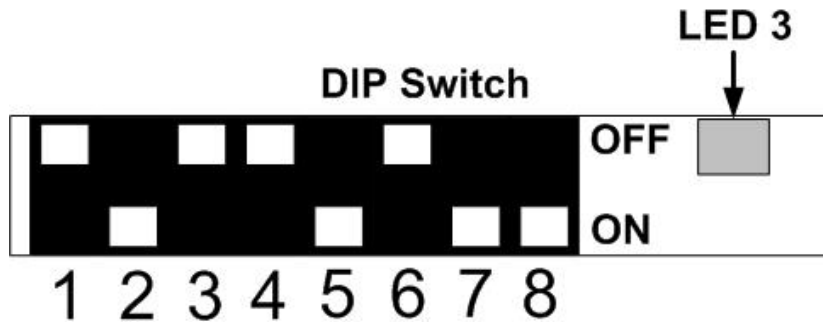

Switch Settings

Below the switch settings for the 6-position dip-switch are defined. Please see the section following the table for more detail on the switch function.

Switch	Setting	Function
1	ON	Local control enabled (toggle for require)
	OFF	Local control disabled
2	ON	RGB component output
	OFF	YUV component output
3	ON	Selection on switch 2 enabled
	OFF	Composite and S- Video output
4	ON	Active line length 720 pixels
	OFF	Active line length 702 pixels
5	ON	Test signal ON (Color Bars)
	OFF	Test signal OFF (Color Bars)
6	ON	Test signal = NTSC format
	OFF	Test signal = PAL format
7	ON	If no input, output = BLACK
	OFF	If no input, output = color bars
8		Not used

Switch Function Detail

All settings are stored in Flash Ram inside the module (see Auto Store section in this manual). Settings will be recalled on power up. It is recommended that switch 1 is set to **OFF** to disable further local control when the module is configured for use.

Dip Switch 1

This switch enables local control using the dip-switches. **ON** enables local control and makes selections on the dip-switch active, and **OFF** disables local control (locking out any changes). If local control is disabled from remote (LED 3 OFF), please toggle Dip Switch 1 to require local control

Dip Switch 2

This switch selects either RGB or YUV component analog outputs from the module. Only active when switch 3 is set to **ON**.

Dip Switch 3

This is used to select the Composite Y/C (S-Video) outputs from the module. **OFF** selects Composite and S-Video outputs. **ON** makes the selection on switch 2 active

Dip Switch 4

This is used to set the active line length to either digital blanking or analog blanking .
ON active line length 720 pixels (digital blanking),
OFF active line length 702 pixels (analog blanking)

Dip Switch 5

This will select the internal color bar test signal from the module which is available on all outputs in the video standard selected.

Dip Switch 6

Selects the output mode for the test signal.

ON for NTSC, **OFF** for PAL

Dip Switch 7

Selects the output signal if no input signal is present.

ON selects signal BLACK,

OFF selects signal COLOR BARS

Factory Preset Condition

The C DA 3002 is delivered preset for the following mode of operation:

- Local control ENABLED
- Composite and S-Video Output
- Active line length 720 pixels
- Test signal OFF
- Test signal format PAL
- If no input output signal = COLOR BARS

If this is the mode of operation required, then no adjustments are necessary.

Alarm/LED Status Indicators

The C DA 3002 module has built in LED indicators, which serve as alarm and status indication for the module. Function is described below. The Indicators are found on the bottom of the module and can be seen through the access holes provided (Fig. 2)

Module Edge Status LED (per channel)

LED	COLOR	
1	GREEN	Input Signal present
	RED	Input Signal lost
2	GREEN	Input Standard PAL
	YELLOW	Input Standard NTSC
3	GREEN	Local Control enabled

Alarm Indicator

There is also a single alarm LED on the front side of the module, which is designed for quick and easy indication of a problem condition in installations where visible access to the bottom of the module is not convenient.

LED Color	Indication
Green	Both input signals present (PLL lock / signal lock)
Yellow	Test pattern selected (color bars) or only one input signal present
Red	No input video signal

LED **OFF** indicates power is lost, or there is a power supply fault.

Locate Function

For large systems which have many modules in various locations we have added a utility which will help visually identify a module quickly. (When used in conjunction with the optional control system and software)

Once the module has been identified on the control system it is possible to initiate the "locate" function and flash the module LEDs yellow in the following continuous sequence.

3 short flashes.... Pause.... 3 short flashes ...

This uses the alarm LED located on the front of the module as well as any module edge LEDs that may be used in the module.

Use of the locate function will not interfere with the normal operation of the module.

For more details on this feature please check the documentation supplied with the controller software

Auto Store

If no parameters are changed for 10 seconds then the current settings will be written into flash memory automatically, this can be seen by the front LED flashing yellow four times.

Specifications *(C DA 3002)*

Inputs

SDI Video	Dual converter. Each channel has 1 serial digital video input. SMPTE 259M-C
Input Impedance	75 Ohm
Connection	BNC
Cable length	250m Belden 8281 (270Mbit/s)
Return Loss	> 15dB (270MHz)

Outputs (digital)

SDI Outputs	Dual converter. Each channel has 1 serial digital video reclocked loop output. SMPTE 259M-C
Output Impedance	75 Ohm, BNC connection.
Return Loss	> 15dB (270MHz)
Output Level	0.8V p-p (nominal)
Jitter	< 0.2 UI

Outputs (analog)

Analog Outputs	75 Ohm BNC connection
Output Level	0.7v p-p (nominal)
Return Loss	> 35dB (5,75MHz)
Signal to Noise	< -60 dB (digital input black)

Operating Modes (independent for each channel)

Outputs	(RGB or YUV) or (S-Video and CVBS)
TV Standard	NTSC or PAL (selectable)
Test	Internal Color Bars
Sync	Sync on RGB (selectable)

Performance

Control	Local settings (dip switch) for each channel.
Status Monitoring	Signal presence detection for each channel

Electrical Specifications

Operating Voltage	+ 5VDC
Power Consumption	3,5 VA
Connection	DC input via 5 pin locking bayonet connector
Safety	IEC 60950/ EN 60950/VDE 0805

Mechanical

Size	85.5mm x 35.3mm x 38.7mm + connectors
Weight	250g

Ambient

Temperature	5°C to 35°C Maintaining specifications -20°C to +70°C Storage
Humidity	Max 80% non condensing

Supplied Accessories

Documentation	C DA 3002 Reference Manual
---------------	----------------------------

Available Options

Below is a list of available options for the C DA 3002 MiniModule. Please refer to product brochures or our web site for more detailed information.

Model	Description
R PS 3001 E	External brick power supply module for Series 3000 MiniModules. European market version. 100-240 VAC input, +5V DC output.
R PS 3001 U	External brick power supply module for Series 3000 MiniModules. USA market version. 110-240 VAC input, +5V DC output.
R PS 3001-3	External desk power supply for Series 3000 Modules. 110-240 VAC input, +5V DC out
R PS 3004	External desk power supply for 4 Series 3000 MiniModules. 110-240 VAC input, 4 x +5V DC output.
R FR 3000	Mounting support for 1 MiniModule
R FR 3004	Mounting support for 4 MiniModules
R FR 3005	This is a basic 19 inch rack mountable frame which can accommodate 10 MiniModules with power bricks R PS 300x or can be extended with the R FR 3010.
R FR 3010	This is a card cage with integrated central power supply, optional redundant power supply and optional controller, which can accommodate 10 MiniModules. Can be combined with R FR 3005
R PS C15	1.5m cable extension to connect one MiniModule to R FR 3010
R PS C25	2.5m cable extension to connect one MiniModule to R FR 3010
R PS 5010	Redundant power supply for the R FR 3010
R CT 5020	Rack controller for the R FR 3010
R CT 5030	Master controller with TCP/IP for the R FR 3010 rack frame
R CT 5010	Rack Bus Extension for R FR 3010 rack frame. In combination with R CT 5020
R CT 3000	Service Adapter for remote configuration of one MiniModule via PC or Palm

Parts List

Due to the very dense design and high level of integration there are no user serviceable electronic assemblies within the C DA 3002 module.

C DA 3002 Mini Module (complete)

Description	Dual Video DA converter
Model Number	C DA 3002
Part Number	6.155.001.284

Service

If you are experiencing problems, or have questions concerning your C DA 3002 MiniModule please contact your local distributor for assistance.

We offer a fixed cost service exchange program for defective Series 3000 MiniModules out of Warranty. Please contact your distributor or check our web site for details on this program.

More detailed information and product updates may be available on our web site:

www.lynx-technik.com

You will also find links to contact us directly for assistance.

Contact Information

Please contact your local distributor; this is your local and fastest method for obtaining support and sales information.

LYNX Technik can be contacted directly using the information below.

Address	LYNX Technik AG Brunnenweg 3 64331 Weiterstadt Germany
Website	www.lynx-technik.com
E-Mail	info@lynx-technik.com

LYNX Technik manufactures a complete range of high quality modular products for broadcast and Professional markets, please contact your local representative or visit our web site for more product information.



