



# Reference Manual

## P VD 3010 B

Media Processor / Frame Synchronizer

Series 3000  
*MiniModules*

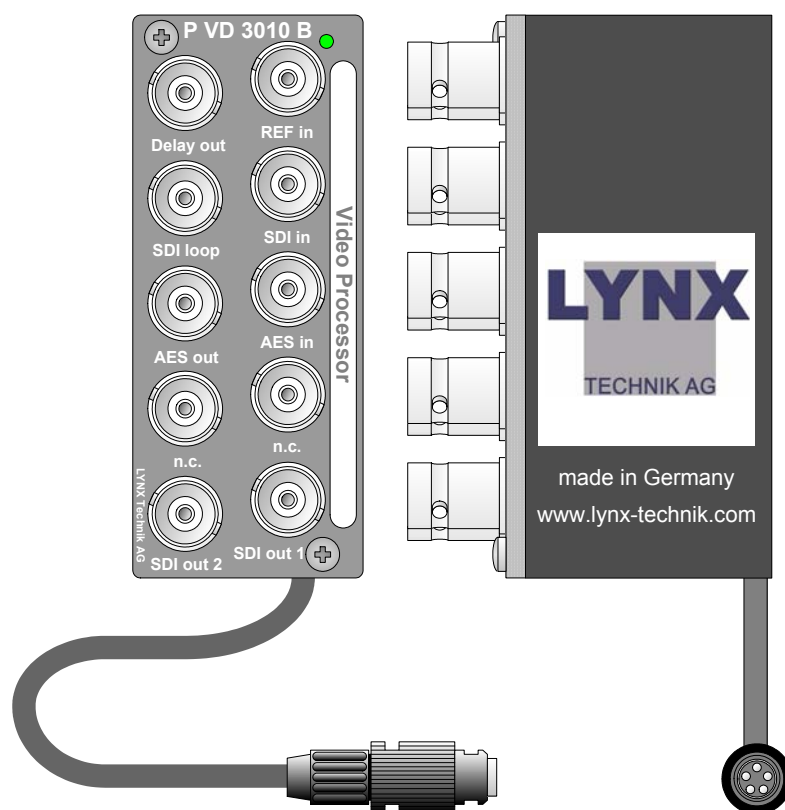

© LYNX Technik AG  
Brunnenweg 3  
64331 Weiterstadt  
Germany  
[www.lynx-technik.com](http://www.lynx-technik.com)

Information in this document is subject to change without notice. No part of this document may be reproduced or transmitted in any form or by any means, electronic or mechanical for any purpose, without express written permission of LYNX Technik AG.

LYNX Technik AG may have patents, patent applications, trademarks, copyrights or other intellectual property rights covering the subject matter in this document. Except as expressly written by LYNX Technik AG, the furnishing of this document does not give you any license to patents, trademarks, copyrights or other intellectual property of LYNX Technik AG or any of its affiliates.

© LYNX Technik AG 2002 all rights reserved

# Warranty

LYNX Technik AG warrants that the product will be free from defects in materials and workmanship for a period of two (2) year from the date of shipment. If this product proves defective during the warranty period, LYNX Technik AG at its option will either repair the defective product without charge for parts and labor, or will provide a replacement in exchange for the defective product.

In order to obtain service under this warranty, customer must notify LYNX Technik of the defect before expiration of the warranty period and make suitable arrangements for the performance of service. Customer shall be responsible for packaging and shipping the defective product to the service center designated by LYNX Technik, with shipping charges prepaid. LYNX Technik shall pay for the return of the product to the customer if the shipment is within the country in which the LYNX Technik service center is located. Customer shall be responsible for payment of all shipping charges, duties, taxes and any other charges for products returned to any other locations.

This warranty shall not apply to any defect, failure, or damage caused by improper use or improper or inadequate maintenance and care. LYNX Technik shall not be obligated to furnish service under this warranty a) to repair damage resulting from attempts by personnel other than LYNX Technik representatives to install, repair or service the product; b) to repair damage resulting from improper use or connection to incompatible equipment; c) to repair any damage or malfunction caused by the use of non LYNX Technik supplies; or d) to service a product which has been modified or integrated with other products when the effect of such modification or integration increases the time or difficulty servicing the product.

**THIS WARRANTY IS GIVEN BY LYNX TECHNIK WITH RESPECT TO THIS PRODUCT IN LIEU OF ANY OTHER WARRANTIES, EXPRESS OR IMPLIED. LYNX TECHNIK AND ITS VENDORS DISCLAIM ANY IMPLIED WARRANTIES OF MERCHANTABILITY OR FITNESS FOR A PARTICULAR PURPOSE. LYNX TECHNIK`S RESPONSIBILITY TO REPAIR AND REPLACE DEFECTIVE PRODUCTS IS THE SOLE AND EXCLUSIVE REMEDY PROVIDED TO THE CUSTOMER FOR BREACH OF THIS WARRANTY. LYNX TECHNIK AND ITS VENDORS WILL NOT BE LIABLE FOR ANY INDIRECT, SPECIAL, INCIDENTAL, OR CONSEQUENTIAL DAMAGES IRRESPECTIVE OF WHETHER LYNX TECHNIK OR THE VENDOR HAS ADVANCE NOTICE OF THE POSSIBILITY OF SUCH DAMAGES.**

# Regulatory information

## Europe

### Declaration of Conformity

We	LYNX Technik AG Brunnenweg 3 D-64331 Weiterstadt Germany
<i>Declare under our sole responsibility that the product</i>	
TYPE: P VD 3010 B	
<i>To which this declaration relates is in conformity with the following standards:</i>	
EN 55103-1 /1996	
EN 55103-2 /1996	
EN 60950 /2001	
<i>Following the provisions of 89/336/EEC and 73/23/EEC directives.</i>	
	Winfried Deckelmann
Weiterstadt, Oktober 2003	
<i>Place and date of issue</i>	<i>Legal Signature</i>

## USA

### FCC 47 Part 15

This device complies with part 15 of the FCC Rules. Operation is subject to the following two conditions: (1) This device may not cause harmful interference, and (2) this device must accept any interference received, including interference that may cause undesired operation.

Note: This equipment has been tested and found to comply with the limits for a Class A digital device, pursuant to the part 15 of the FCC Rules. These limits are designed to provide reasonable protection against harmful interference when the equipment is operated in a commercial environment. This equipment generates, uses, and can radiate radio frequency energy and, if not installed and used in accordance with the instruction manual, may cause harmful interference to radio communications. Operation of this equipment in a residential area is likely to cause harmful interference in which case the user will be required to correct the interference at his own expense

# Contents

<b>Warranty .....</b>	<b>3</b>
<b>Regulatory information.....</b>	<b>4</b>
Europe.....	4
Declaration of Conformity.....	4
USA.....	4
FCC 47 Part 15.....	4
<b>Contents .....</b>	<b>5</b>
<b>Getting Started.....</b>	<b>7</b>
Packaging.....	7
Product Description.....	7
Key Features.....	8
Functional Diagram.....	9
Module Layout.....	10
<b>Connections.....</b>	<b>10</b>
Video Connections.....	10
Audio Connections (option).....	10
Audio Delay output.....	10
Audio Delay Pulse.....	11
GPI.....	<b>Fehler! Textmarke nicht definiert.</b>
Power Connections.....	13
DC Power Connector.....	13
<b>Installation.....</b>	<b>14</b>
Mechanical.....	14
Stand Alone Operation.....	14
Multiple Units.....	15
Electrical Installation.....	16
Stand Alone Operation.....	16
Multiple Units.....	17
<b>Settings and Control.....</b>	<b>17</b>
Switch Settings.....	18
Up / Down Buttons.....	18
Switch Function Detail.....	19
Adjustment Procedure.....	20
Factory Preset Condition.....	20
<b>Alarm/LED Status Indicators.....</b>	<b>21</b>
Channel Condition Indicators.....	21
Front Panel Alarm Indicator.....	21
Locate Function.....	22
<b>Specifications (P VD 3010 B).....</b>	<b>23</b>
<b>Available Options.....</b>	<b>24</b>
<b>Parts List.....</b>	<b>25</b>
<b>Service.....</b>	<b>25</b>
<b>Contact Information.....</b>	<b>26</b>

*This page is intentionally left blank*

# Getting Started

## Packaging

The shipping carton and packaging materials provide protection for the module during transit. Please retain the shipping cartons in case subsequent shipping of the product becomes necessary.

## Product Description

The P VD 3010 B is a high quality frame designed primarily for broadcast and professional applications.

The SDI input can be synchronized to external sync with a delay of 19ms to a maximum of 8 frames adjustable in 37ns increments. A separate delay output is provided for external audio delay processing and with the addition of the audio option, external Audio can be processed directly inside the module. The module connection plate is prepared for AES3-id unbalanced audio input/output.

The modules can be used either stand alone using the optional power supply brick, or as part of a tightly integrated space saving system where up to 10 MiniModules can be mounted utilizing the optional LYNX R FR 3005 / 3010 rack housing. This includes integrated power supply and optional remote control interfaces.

The optional LYNX Service Adapter and control software can be used for stand-alone configuration using a PC.

## Key Features

- Dual standard operation (525/625)
- Delay range of 1 $\mu$ s to 8 frames max in 37ns increments
- Delay output pulse for external audio delay processor
- Advanced Video Processor option adds features such as Noise reduction, Color Correction and a Legaliser
- Audio option adds internal audio processing. Embedded, or external AES
- Local DIP-switch, push buttons and LED's for local control and status monitoring
- Microprocessor controlled
- Flash Ram storage for settings
- Remote control interface



# Functional Diagram

Figure 1 below is the basic functional diagram for the P VD 3010 B MiniModule.

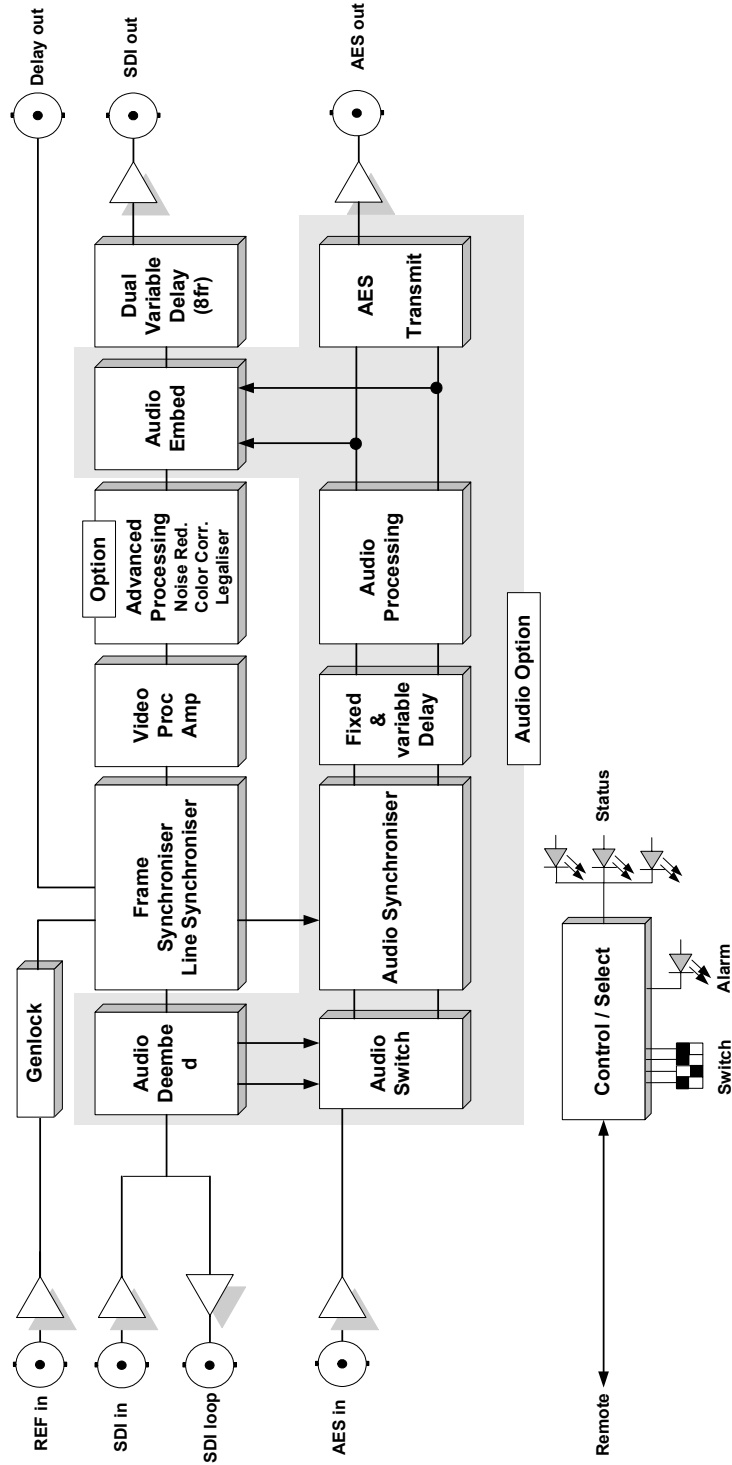

Figure 1- P VD 3010 B Functional Diagram

## Module Layout

Figure 2 shows the physical layout of the P VD 3010 B MiniModule. This module uses BNC connectors for digital video and AES audio input and output. (Audio option and Advanced Video option sold separately)

*If the module is being used in a stand alone application then the optional power supply (R PS 3001 E or R PS 3001 U) is required to power the module (not shown)*

## Connections

### Video Connections

The P VD 3010 B MiniModule is configured with standard 75 Ohm BNC connectors. Connection is self-explanatory. We recommend the use of high quality video cable to reduce the risk of interference or errors due to excessive cable attenuation.

### Audio Connections (option)

The connection panel is fitted with BNC connectors for AES digital audio (un-balanced AES3-id). If this option is not installed these connections will not be active.

### Audio Delay output

The module provides a TTL pulse whose duty cycle corresponds to the video delay in the synchronizer. This can be used for the external delay of audio signals. The signal represents the actual delay between the incoming SDI signal and the SDI output

**Note.** *Due to the compact design of the rear connection plate it will be necessary to use a connection tool to secure the BNC connectors to the module.*

## Audio Delay Pulse

The Audio Delay Pulse is connected through a BNC connector with TTL levels and needs 75 Ohm termination.

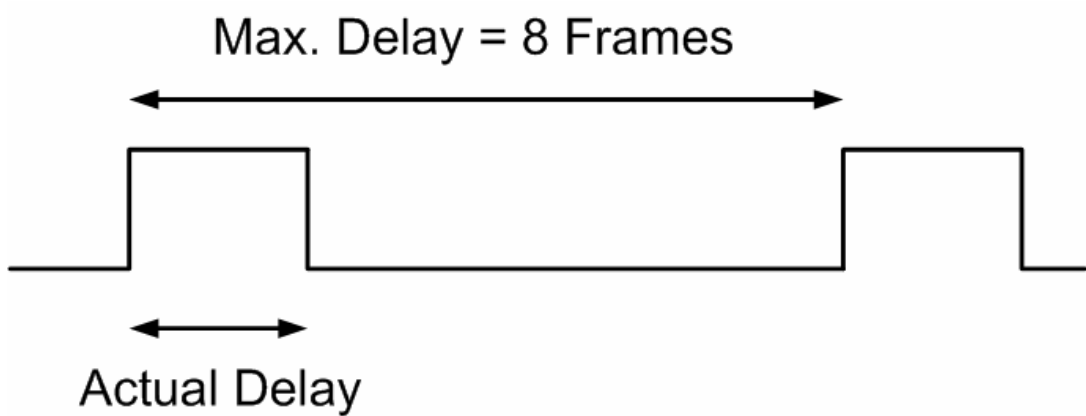

Min. Delay in Frame Synch Mode is 1 Frame  
Min. Delay in Line Synch Mode is  $< 1\mu\text{s}$

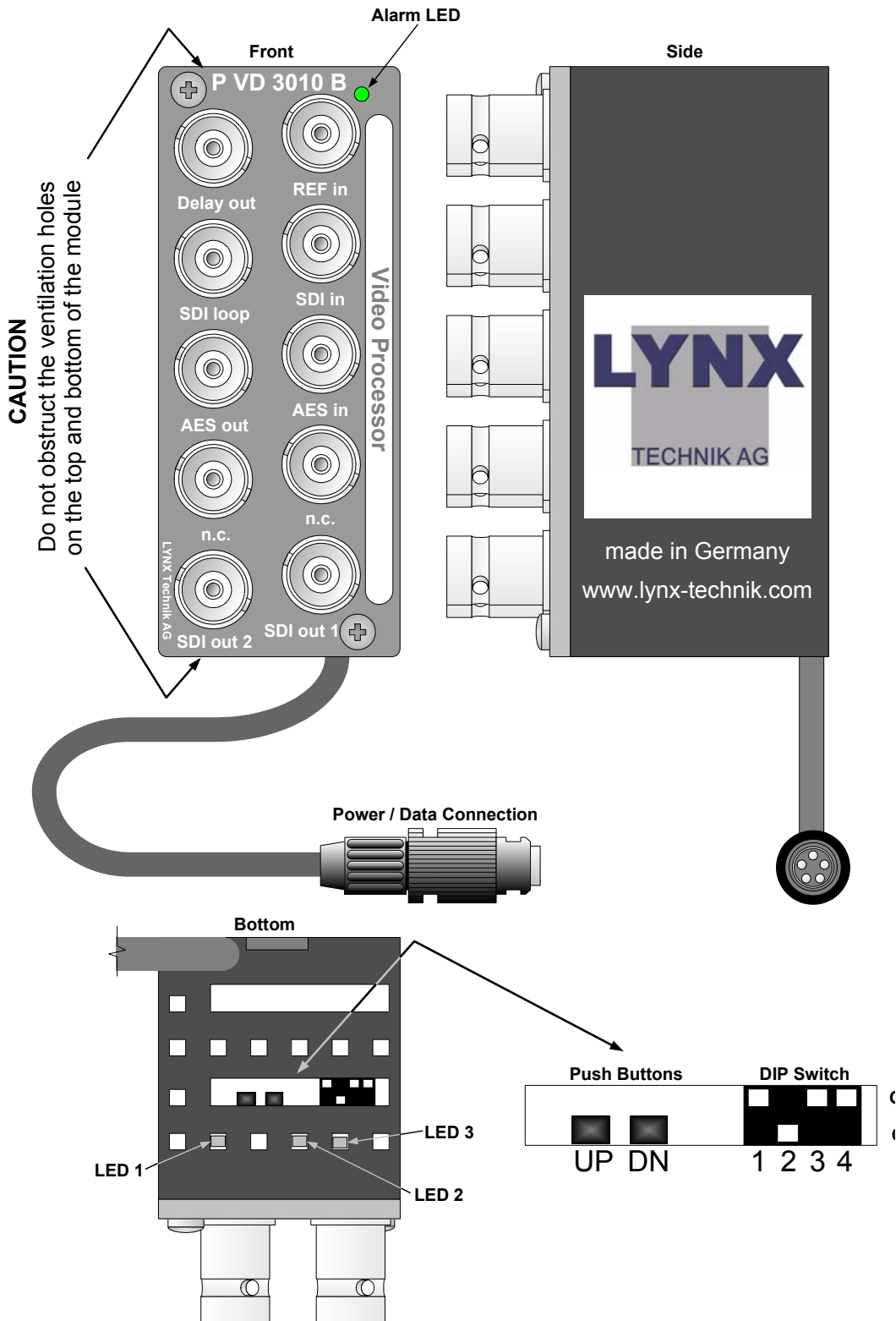

## Power Connections

If using the module in a stand-alone application use the separate R PS 3001 E (for Europe, R PS 3001 U (USA) power brick option or the desk power supply R PS 3001-3.

### DC Power Connector

The MiniModule has a captive power lead fitted to the module, with a male 5 pin locking bayonet connector. This connection provides DC power and also data connectivity to the module. Connector wiring is shown below.

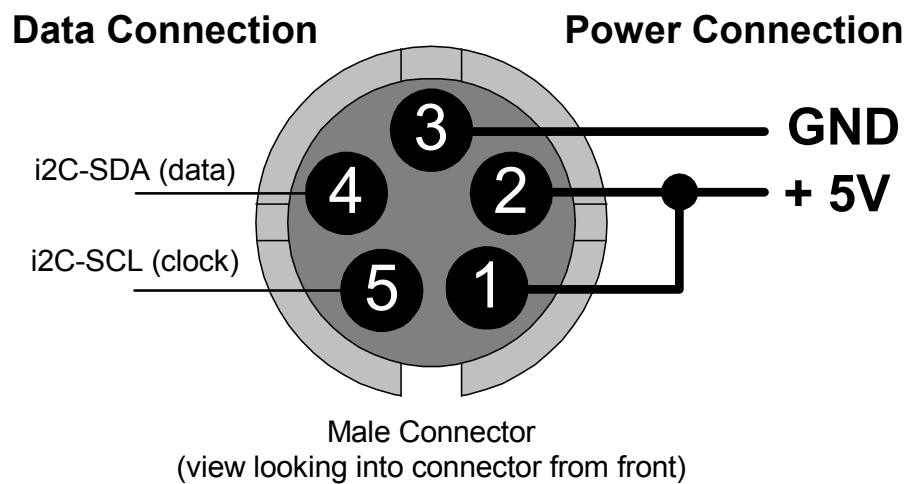

#### Caution

Only use the optional LYNX R PS power modules. Ensure the 5-pin power connector is locked securely in place.

# Installation

## Mechanical

### Stand Alone Operation

The P VD 3010 B MiniModule can be used in a stand-alone application. There are two options for the use of the module in this way.

- a) Using the R FR 3005 Rack Frame 1 option. This allows up to any 10 of the MiniModules to be secured onto a rack frame assembly for 19 inch rack mounting. This keeps the modules secured, organized and out of the way. The R PS 3001 power brick option or the R FR 3010 option is required to power each module. Please refer to the R FR 3005 Reference Manual supplied with this option for more details.
- b) Single Use. The MiniModule can be powered independently with the R PS 3001 option and used in any location where this functionality is required.



**Caution.** Care needs to be taken when using the module in this way, as it is not physically secured. Keep the module away from the floor to avoid the risk of someone stepping or tripping on the unit, and locate the unit away from excessive sources of heat and any sources or moisture.

*If using more than one MiniModule in any installation, the R FR 3005/3010 Rack frame combination is highly recommended.*

## Multiple Units

Most applications will require more than one MiniModule, which can include any of the available Series 3000 MiniModule product range. There are two options for mounting multiple units.

- a) Using the R FR 3005 Rack Frame option. This allows up to any 10 of the MiniModules to be secured onto a rack frame assembly for 19 inch rack mounting. The R PS 3001 power brick option or the R FR 3010 option is required to power each module. Please refer to the R FR 3005 Reference Manual for more details.
  
- b) Using the R FR 3010 Rack frame extension option. Can be combined with the R FR 3005 Rack frame option. Each module plugs into a connection bus, which provides common power for all modules. (No R PS external power supplies are needed). Remote control and status monitoring of all modules is possible with the addition of the R CT 5020 rack controller and R CT 5030 master controller options. Please refer to the respective reference manuals for these options for details of mechanical installation.

The very small size and density of the MiniModules combined with the available rack frame options allows the addition of a complex and custom signal distribution system without taking any additional front rack space. The rack frames are designed for installation in the back of 19-inch racks where there is normally plenty of available space. Ideal for mobile truck installations and facility expansions where space is at a premium.

# Electrical Installation.

## Stand Alone Operation

The MiniModule requires the R PS 3001 power brick option for stand-alone operation. Three versions are available: R PS 3001 E for European markets, R PS 3001 U for the US markets and the desk power supply R PS 3001-3. Please ensure you have the correct power option for your region. The connection to the module is made with a small 5-pin connector, which has a twist bayonet securing system. Please make sure the connection is solid and locked in place. A strain relief is included within the module to prevent excessive strain on the connection.

Signal connections should be made with care, please ensure connections are correct and compatible equipment is feeding / receiving the signals from the module or damage can result.



**Caution.** Only use the optional LYNX R PS 3001 power modules. Ensure the 5-pin power connector is locked securely in place.



**Caution.** Care needs to be taken when using the module in this way, if it is not physically secured. Keep the module away from the floor to avoid the risk of someone stepping or tripping on the unit, and locate the unit away from excessive sources of heat and any sources or moisture.



## **Multiple Units**

When installing multiple MiniModule units it is recommended you use the R FR 3005 Rack Frame 1 and / or R FR 3010 Rack Frame 2 options. Please refer to the documentation supplied with these options for details on electrical installation.

## **Settings and Control**

The P VD 3010 B has an integrated micro-controller, which enables the module to be configured and controlled locally via the integral dip-switch and push buttons, or from remote when using the optional R CT 3000 Service Adapter or R FR 3010 Rack Frame and control system.

Once set, (either locally or via remote) all settings are automatically saved in internal flash ram. The module will always recall the stored settings when powered up.

The module local configuration is performed from a 4-position dip-switch and up/down adjustment buttons which are accessible through an access space in the bottom of the module.

Please refer to Figure 2 for the location of these adjustments.

## Switch Settings

Below the switch settings for the 4-position dip-switch are defined. Located next to the switch are two push buttons [UP/DN] these are for delay adjustments. Refer to figure 2



Switch functions are explained in more detail following the table.

Switch	Setting	Function
1	ON	Enable Local Adjustment
	OFF	Disable Local Adjustment
2	ON	Frame Freeze
	OFF	Field 2 Freeze
3	ON	Blanking Active
	OFF	Blanking Transparent
4	ON	
	OFF	

### Up / Down Buttons

The push buttons are used to adjust the delay of the Synchronizer.

**UP.** When pressed the delay will be continuously increased until released.

**DN** When pressed the delay will be continuously decreased until released.

**Note.** Adjustment range delay to 8 frames maximum with step increments of 37ns.

## Switch Function Detail

**Switch 1.** This switch is used to enable or disable local adjustments. When set to **ON** the system will accept any change on switches 2 through 4. When set to **OFF** any switch settings that are changed will have no effect. This switch is also used to toggle between Pixel or Line adjustment mode (*Please see adjustment procedure*)

**Switch 2.** This is used to select the freeze mode for the module. **ON** selects FRAME freeze **OFF** selects FIELD 2 freeze.

**Switch 3** This is used to define if the module will add new vertical and horizontal blanking to the outgoing video signal (blanking off any information which may have been in the incoming signal). **ON** will make blanking active, **OFF** will disable this function and pass whatever blanking information is on the input signal through to the output.

## Adjustment Procedure

It is possible to independently adjust the pixel and line delay on the module using the dip-switch and the **UP/ DOWN** buttons.

1. Set Switch 1 to ON (enable local adjustment).
2. Observe LED 3, (figure 2) this can be in two states:
  - **ON** Indicates the module is in **PIXEL** adjustment mode.
  - **BLINKING** Indicates the module is in **LINE** adjustment mode.

**Note.** To change between **PIXEL** and **LINE** mode toggle Switch 1 **ON-OFF-ON**

3. Using the UP/DOWN push buttons adjust the PIXEL or LINE delay to the desired value.
4. When Complete set Switch 1 to **OFF**.

## Factory Preset Condition

The P VD 3010 B is delivered with stored presets for the following functionality.

Delay: **0**  
Blanking: **Transparent**

No further adjustments are needed if this is the functionality desired.

## Alarm/LED Status Indicators

The P VD 3120 B module has built in LED indicators that serve as alarm and status indication for the module. Function is described below.

The Indicators are found on the bottom of the module and can be seen through the access holes provided. (Figure 2)

### Channel Condition Indicators

Three multicolor LED's are provided to indicate the module status and the following conditions:

LED #	Color	Indication
1	Green	External ref = 525/60Hz
	Yellow	External ref = 625/50Hz
	Red	Input missing or invalid signal
2	Green	SDI input 1 detected as 525/60Hz
	Yellow	SDI input 1 detected as 625/50Hz
	Red	Input missing or invalid signal
3	Green ON	PIXEL adjust mode selected
	Green BLINK	LINE adjust mode selected
	OFF	Local delay adjustment disabled

### Front Panel Alarm Indicator

There is also a single alarm LED on the front side of the module, (figure2) which is designed for quick and easy indication of a problem condition in installations where visible access to the bottom of the module is not convenient.

LED Color	Indication
Green	Normal operation.
Red	Critical failure.
Off	<i>Power Supply Fault</i>

Normal status is **GREEN**

## Locate Function

For larger systems which may have multiple modules of the same type mounted in a single rack frame, or multiple rack frames on a large central control system we have added a useful utility which will help to visually locate a suspect module quickly (When used in conjunction with the optional control system and software)

Once the specific module has been selected on the control system there is a locate button on the top of the GUI:

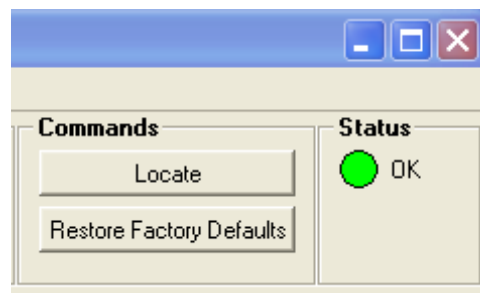

Locate Function in Control System

When Locate is selected the status indicator on the GUI and the module LED's will flash yellow in the following continuous sequence.

### **3 short flashes.... Pause.... 3 short flashes ...**

This uses the alarm LED located on the front of the module and in some cases any channel or status LED's that may also be used in the module.

Use of the locate function will not interfere with the normal operation of the module.

For more details on this feature please check the documentation supplied with the controller software.

# Specifications *(P VD 3010 B)*

## Video Input

Signal	SDI (SMPTE 259M-C)
Input Impedance	75 Ohms
Connection	BNC
Cable Length	250 m Belden 8281 (270Mbit/s)
Return Loss	> 15dB (270 MHz)

## Reference Input

Signal	Composite analog sync, 525/60Hz or 625/50Hz
Detection	Automatic
Connection	BNC
Impedance	75 Ohms

## Output

Signal	SDI (SMPTE 259M-C)
Connection	BNC
Impedance	75 Ohms
Return Loss	> 15dB (270 MHz)
Jitter	< 0.2 UI

## Delay Output

Signal	TTL pulse duty cycle = delay from input to output
Conenction	BNC, 75 Ohm

## Operating Modes

Line	Line Synchronizer
Frame	Frame Synchronizer

## Performance

Adjustment range	1 $\mu$ s min to 8 frames max in 37ns increments
Status Monitoring	Local LED's and /or using Lynx controller option
Control	Local switches and or using Lynx controller option

## Electrical Specifications

Operating Voltage	+ 5VDC
Power Consumption	Approx 6.0VA
Connection	DC input via 5 pin locking bayonet connector
Safety	IEC 60950/ EN 60950/VDE 0805

## Mechanical

Size	85.5mm x 35.3mm x 38.7mm + connectors
Weight	250g

## Ambient

Temperature	5°C to 35°C Maintaining specifications
Humidity	Max 90% non condensing

## Supplied Accessories

Documentation	P VD 3010 B Reference Manual and Quick Reference Guide
---------------	--

## Available Options

Below is a list of available options for the P VD 3010 B MiniModule. Please refer to product brochures or our web site for more detailed information.

<b>Model</b>	<b>Description</b>
<b>R PS 3001 E</b>	<b>External brick power supply module for Series 3000 MiniModules. European market version. 100-240 VAC input, +5V DC output.</b>
<b>R PS 3001 U</b>	<b>External brick power supply module for Series 3000 MiniModules. USA market version. 110-240 VAC input, +5V DC output.</b>
<b>R PS 3001-3</b>	<b>External desk power supply module for Series 3000 MiniModules. 110-240 VAC input, +5V DC output.</b>
<b>R FR 3005</b>	<b>Rack Frame 1. This is a basic 19-inch rack mountable frame that can accommodate 10 MiniModules with power bricks R PS 1 or can be extended with the R FR 3010.</b>
<b>R FR 3010</b>	<b>Rack Frame 2. This is a card cage with integrated central power supply, optional redundant power supply and optional controller, which can accommodate 10 MiniModules. Can be combined with R FR 3005</b>
<b>R PS C15</b>	<b>1.5m cable extension to connect one MiniModule to R FR 3010</b>
<b>R PS 5010</b>	<b>Redundant power supply for the R FR 3010 card cage</b>
<b>R CT 5020</b>	<b>Rack controller for the R FR 3010 rack frame</b>
<b>R CT 5010</b>	<b>Rack Bus Extension for R FR 3010 rack frame. In combination with R CT 5020</b>
<b>R CT 3000</b>	<b>Service Adapter for remote configuration of one MiniModule via PC or Palm</b>



## Parts List

Due to the very dense design and high level of integration there are no user serviceable electronic assemblies within the P VD 3010 B module.

### **P VD 3010 B Mini Module (complete)**

Description	Media Processor
Model Number	P VD 3010 B
Part Number	6.155.003.265

## Service

If you are experiencing problems, or have questions concerning your P VD 3010 B MiniModule please contact your local distributor for assistance.

We offer a fixed cost service exchange program for defective Series 3000 MiniModules out of Warranty. Please contact your distributor or check our web site for details on this program.

More detailed information and product updates may be available on our web site:

**[www.lynx-technik.com](http://www.lynx-technik.com)**

You will also find links to contact us directly for assistance.

## Contact Information

Please contact your local distributor; this is your local and fastest method for obtaining support and sales information.

LYNX Technik can be contacted directly using the information below.

<b>Address</b>	LYNX Technik AG Brunnenweg 3 64331 Weiterstadt Germany.
<b>Phone</b>	+ 49 (0) 6150 1817 0
<b>Fax</b>	+ 49 (0) 6150 1817 10
<b>Website</b>	<a href="http://www.lynx-technik.com">www.lynx-technik.com</a>
<b>E-Mail</b>	<a href="mailto:info@lynx-technik.com">info@lynx-technik.com</a>

LYNX Technik manufactures a complete range of high quality modular products for broadcast and Professional markets, please contact your local representative or visit our web site for more product information.



*This page is intentionally left blank*

