

Reference Manual

P MX 3362

SD/HD Analog Audio Embedder

**Revision 1.2
October 2008**



Information in this document is subject to change without notice. No part of this document may be reproduced or transmitted in any form or by any means, electronic or mechanical for any purpose, without express written permission of LYNX Technik AG.

LYNX Technik AG may have patents, patent applications, trademarks, copyrights or other intellectual property rights covering the subject matter in this document. Except as expressly written by LYNX Technik AG, the furnishing of this document does not give you any license to patents, trademarks, copyrights or other intellectual property of LYNX Technik AG or any of its affiliates.

**LYNX Technik AG
Brunnenweg 3
D 64331 Weiterstadt
Germany
www.lynx-technik.com**

Contents

CONTENTS	2
WARRANTY	4
REGULATORY INFORMATION	5
EUROPE	5
<i>Declaration of Conformity</i>	5
USA	5
<i>FCC 47 Part 15</i>	5
RoHS CONFORMITY	6
GETTING STARTED	6
PACKAGING	6
PRODUCT DESCRIPTION	6
KEY FEATURES	6
INPUT FORMATS	7
OUTPUT FORMATS	7
AUDIO SYNC FRAME WITH NO INPUT (AUTO BLACK)	7
INPUT AUDIO CROSSBAR	7
AUDIO GROUP DELETION	7
FUNCTIONAL DIAGRAM	8
MODULE LAYOUT	9
CONNECTIONS	10
VIDEO	10
AUDIO	10
<i>Analog Audio</i>	10
POWER	11
INSTALLATION	12
LOCAL CONTROL	13
SWITCH SETTINGS	13
SWITCH FUNCTION DETAIL	14
<i>Switch 1</i>	14
<i>Switch 2</i>	14
<i>Switch 3</i>	14
<i>Switch 4 to 6</i>	14
<i>Dip Switch 7 and 8</i>	14
FACTORY DEFAULT SETTINGS	14
INDICATORS	15
ALARM INDICATOR	15
LED 1	15
LED 2	15
CONTROL SYSTEM GUI	16
MAIN TAB	17
<i>Input Detection</i>	17
<i>Group Status</i>	17
<i>Signal Standard</i>	18
<i>Audio Analog to Digital Conversion</i>	18

<i>Input Audio Crossbar</i>	18
<i>Embedder</i>	18
EVENTS TAB.....	19
<i>Log in GUI Function</i>	19
<i>Event Enabled</i>	19
<i>SNMP Support</i>	20
COMMON GUI CONTROLS	20
PROPERTIES	20
LOCATE.....	21
NEW CONTROL WINDOW.....	21
<i>Rename</i>	21
<i>Release</i>	22
<i>Lock</i>	22
<i>Reset Factory Defaults</i>	22
SPECIFICATIONS.....	23
SERVICE.....	24
PARTS LIST	24
TECHNICAL SUPPORT	24
CONTACT INFORMATION.....	24

Warranty

LYNX Technik AG warrants that the product will be free from defects in materials and workmanship for a period of two (2) year from the date of shipment. If this product proves defective during the warranty period, LYNX Technik AG at its option will either repair the defective product without charge for parts and labor, or will provide a replacement in exchange for the defective product.

In order to obtain service under this warranty, customer must notify LYNX Technik of the defect before expiration of the warranty period and make suitable arrangements for the performance of service. Customer shall be responsible for packaging and shipping the defective product to the service center designated by LYNX Technik, with shipping charges prepaid. LYNX Technik shall pay for the return of the product to the customer if the shipment is within the country which the LYNX Technik service center is located. Customer shall be responsible for payment of all shipping charges, duties, taxes and any other charges for products returned to any other locations.

This warranty shall not apply to any defect, failure, or damage caused by improper use or improper or inadequate maintenance and care. LYNX Technik shall not be obligated to furnish service under this warranty a) to repair damage resulting from attempts by personnel other than LYNX Technik representatives to install, repair or service the product; b) to repair damage resulting from improper use or connection to incompatible equipment; c) to repair any damage or malfunction caused by the use of non LYNX Technik supplies; or d) to service a product which has been modified or integrated with other products when the effect of such modification or integration increases the time or difficulty servicing the product.

THIS WARRANTY IS GIVEN BY LYNX TECHNIK WITH RESPECT TO THIS PRODUCT IN LIEU OF ANY OTHER WARRANTIES, EXPRESS OR IMPLIED. LYNX TECHNIK AND ITS VENDORS DISCLAIM ANY IMPLIED WARRANTIES OF MERCHANTABILITY OR FITNESS FOR A PARTICULAR PURPOSE. LYNX TECHNIK'S RESPONSIBILITY TO REPAIR AND REPLACE DEFECTIVE PRODUCTS IS THE SOLE AND EXCLUSIVE REMEDY PROVIDED TO THE CUSTOMER FOR BREACH OF THIS WARRANTY. LYNX TECHNIK AND ITS VENDORS WILL NOT BE LIABLE FOR ANY INDIRECT, SPECIAL, INCIDENTAL, OR CONSEQUENTIAL DAMAGES IRRESPECTIVE OF WHETHER LYNX TECHNIK OR THE VENDOR HAS ADVANCE NOTICE OF THE POSSIBILITY OF SUCH DAMAGES.

Regulatory information

Europe

Declaration of Conformity

<i>We</i>	LYNX Technik AG Brunnenweg 3 D-64331 Weiterstadt Germany
	<i>Declare under our sole responsibility that the product</i>
	TYPE: P MX 3362
	<i>To which this declaration relates is in conformity with the following standards (environments E1-E3):</i>
	EN 55103-1 /1996
	EN 55103-2 /1996
	EN 60950 /2001
	<i>Following the provisions of 89/336/EEC and 73/23/EEC directives.</i>
	Winfried Deckelmann
Weiterstadt, September 2007	
<i>Place and date of issue</i>	<i>Legal Signature</i>

USA

FCC 47 Part 15

This device complies with part 15 of the FCC Rules. Operation is subject to the following two conditions: (1) This device may not cause harmful interference, and (2) this device must accept any interference received, including interference that may cause undesired operation.

Note: This equipment has been tested and found to comply with the limits for a Class A digital device, pursuant to the part 15 of the FCC Rules. These limits are designed to provide reasonable protection against harmful interference when the equipment is operated in a commercial environment. This equipment generates, uses, and can radiate radio frequency energy and, if not installed and used in accordance with the instruction manual, may cause harmful interference to radio communications. Operation of this equipment in a residential area is likely to cause harmful interference in which case the user will be required to correct the interference at his own expense

RoHS Conformity



The RoHS Directive stands for "the restriction of the use of certain hazardous substances in electrical and electronic equipment". This Directive bans the placing on the EU market of new electrical and electronic equipment containing more than agreed levels of lead, cadmium, mercury, hexavalent chromium, polybrominated biphenyl (PBB) and polybrominated diphenyl ether (PBDE) flame retardants.

This product conforms to EU RoHS Directives 2002/95/EC

Getting Started

Packaging

The shipping carton and packaging materials provide protection for the module during transit. Please retain the re-useable shipping cartons for a period of time in case subsequent shipping of the product becomes necessary. Please read this manual before attempting operation of the module.

Product Description

The P MX 3362 is a high quality multi-format analog audio embedder suitable for use in SDTV applications and new HDTV applications, with support for a variety of HDTV formats.

The P MX 3362 is a 4 channel device and will accept 4 x analog audio streams 2 x stereo).

The module is multi-format and multimode in operation. The input video standard (and format) is detected and the module automatically switches its operation to the detected format.

The module also provides 4 x SDI outputs so it can also fill the role of a multi-format 1 > 4 re-clocking distribution amplifier.

Key Features

- Support for SDTV and HDTV standards
- Automatic video standard and format detection
- Existing embedded audio detection
- Delete or replace existing embedded audio
- Monaural audio input crossbar
- Embedded audio group selection
- Black output audio sync frame with no SDI input signal
- 4 x SDI outputs

Input Formats

The module has one multi-format serial digital input with automatic input detection. The module will detect the following input standards and configure the input stage automatically for operation in the connected format.

SDTV Formats	HDTV Formats
525 / 59.94Hz	1080i / 59.94Hz
625 / 50Hz	1080i / 60Hz
	1080i / 50Hz
	720P / 59.94Hz
	720P / 60Hz
	720P / 50Hz

Output Formats

Four serial digital outputs are provided. The format is the same as the input format, or the pre-selected format if no input is connected (auto black function, see below).

Audio Sync Frame with No Input (auto black)

With no SDI signal connected the module will (default) to the last connected video standard and will produce a black video output with the audio embedded.

If used in standalone mode with no SDI input connected the output standard can be changed from the default using the format selections provided in the GUI or local menus.

Note. The modules are supplied with set with “*default to the last connected video standard*”. This will be 1080i / 50Hz for new modules. This can be cleared by connecting a different video input, or by selecting the required video format (using the selections provided) – waiting approx 10 seconds for the module LEDs to flash yellow three times and then switching it back to “*follow last input*”. This will have the same effect.

If the SDI video input is removed during operation, then the embedder will continue to embed audio onto a black video frame in the selected format until the video is restored.

Input Audio Crossbar

Each audio input is fed into a monaural audio crossbar where individual left and right audio channels can be re-assigned / swapped prior to embedding.

Note. The mono switching function is only accessible using the Module GUI via the control system.

Audio Group Deletion

The embedder will detect any audio groups present in the SDI stream, and each group can be selected individually. The user has the choice of passing any existing embedded audio group(s) intact, replacing the audio group(s) or deleting the audio group(s).

Note. Settings will be written to flash RAM automatically after 10 seconds with no activity. This can be observed by the alarm LED flashing yellow three times. If power is removed before the settings have been stored the module will revert back to the previous settings when powered up

Functional Diagram

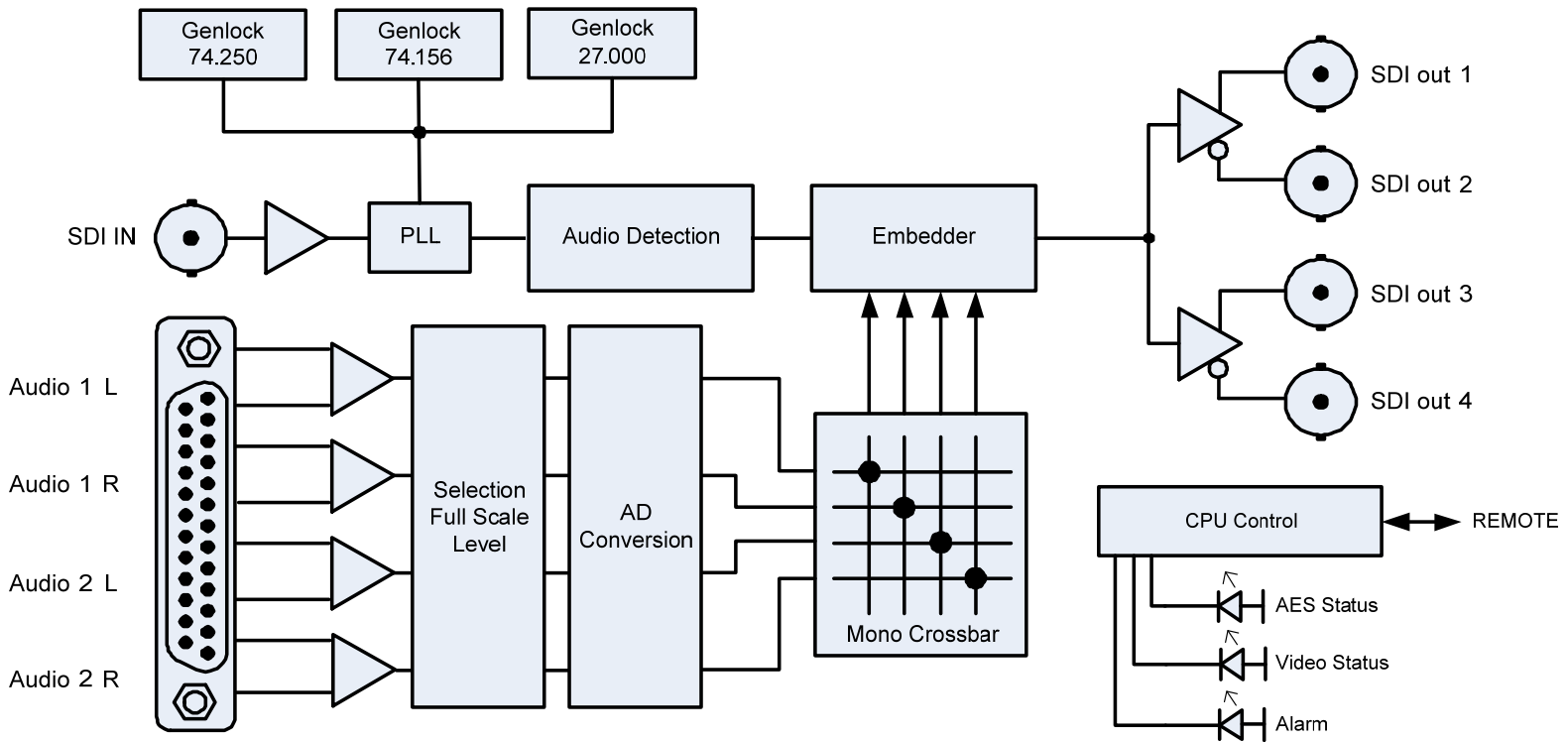

Module Layout

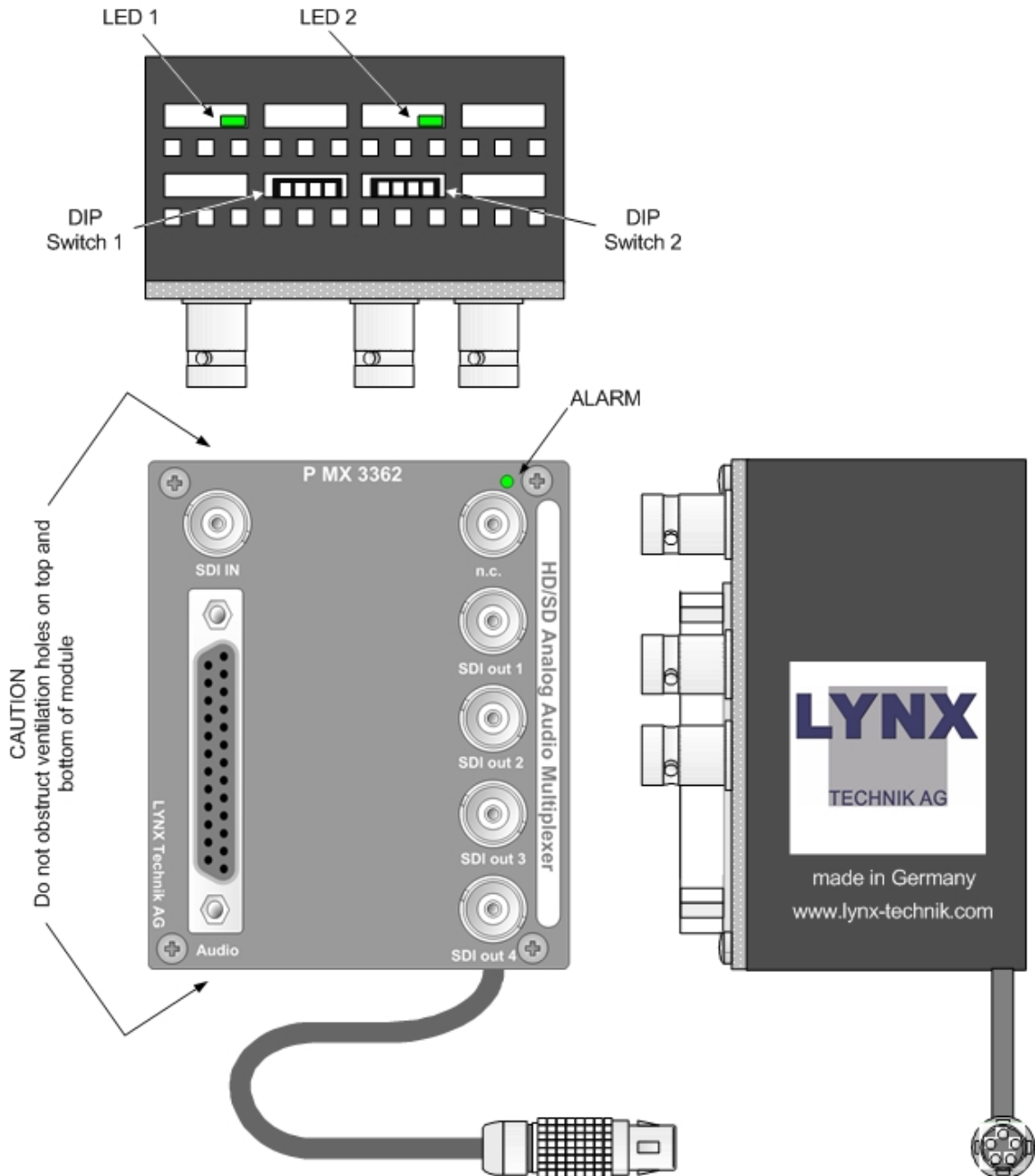

Connections

Video

The P MX 3362 uses standard 75 Ohm BNC connectors. We recommend the use of high quality video cable for digital video connections to reduce the risk of errors due to excessive cable attenuation. Max cable lengths the module will support are shown below.

SDTV = 250m Belden 8281 (270Mbits/s)
 HDTV = 100m Belden 1694A (1.485Gbits/s)

Audio

Analog Audio

Balanced connections are made via the 25 pin SubD connector. Connection details shown below.

Pin Number	Connection	Pin Number	Connection
1	+ IN Left 1	14	- IN Left 1
2	GND IN Left 1	15	+ IN Right 1
3	- IN Right 1	16	GND IN Right 1
4	+ IN Left 2	17	- IN Left 2
5	GND IN Left 2	18	+ IN Right 2
6	- IN Right 2	19	GND IN Right 2
7	(n.c)	20	(n.c)
8	(n.c)	21	(n.c)
9	(n.c)	22	(n.c)
10	(n.c)	23	(n.c)
11	(n.c)	24	(n.c)
12	(n.c)	25	(n.c)
13	(n.c)		

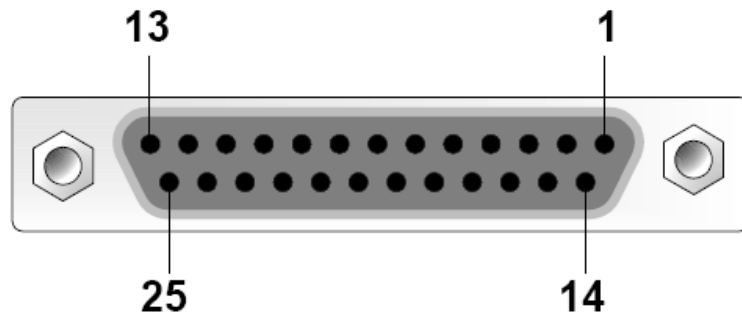

View looking INTO connector as seen on module

We recommend you use high quality screened (twisted pair) cable for the balanced audio connections. LYNX has an optional audio breakout cable which will bring out all audio connections to in line XLR connectors. Model number **R AC F25-8**

Power

The module requires a + 5VDC power supply. There are various power options available by LYNX which includes AC power adapters and various battery adapters. Please refer to the LYNX catalog for more details on available power supply options.

The connector used on the module is a LEMO connector which connects both power and data connections to the module. Connection information is shown below. The data interface is used for the optional central control system or RCT 3002 USB Service Adapter.

The LEMO connector has a metal key and can be aligned by using the red dots on both connectors and then pushed together until locked into place. When connected correctly this will provide a secure mechanical connection.

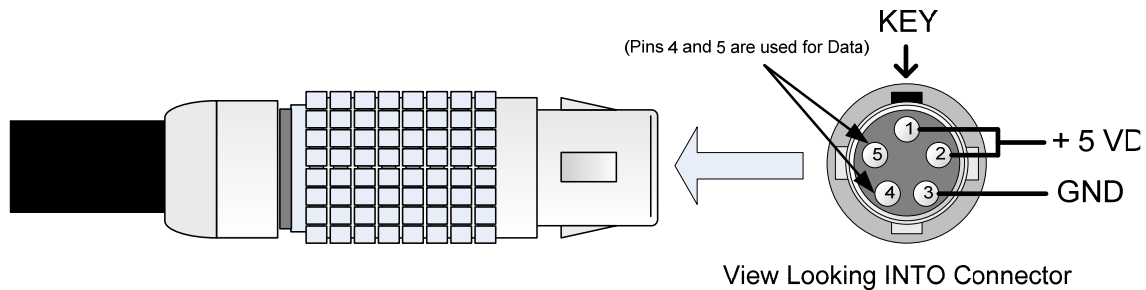

If you are providing your own power source please ensure it can provide enough power and provides a clean + 5VDC supply with a tolerance of + 4.95VDC to +5.10VDC (under load measured at the connector). We recommend the use of screened power cable connecting the screen to the ground pin.

DO NOT MAKE ANY CONNECTIONS TO PINS 4 and 5 AS THESE ARE FOR DATA CONNECTIONS (LYNX USE ONLY). CONNECTING POWER TO THESE PINS WILL RESULT IN MODULE DAMAGE.

A suitable mating connector may be purchased directly from LYNX or LEMO directly www.lemo.com. Lemo Part number for mating connector is **FGG.0B.305.CLAD42**

Note

Any failure or damage to the module resulting from the use of a non LYNX supplied power source (or adapter) is not covered under warranty

Installation

The MiniModule can be used standalone in any suitable location. The location should be free from any moisture and excessive sources of heat. The ventilation holes in the top and the bottom of the module should be kept un-obstructed at all times or module overheating may occur and result in module damage.

Note. *The module may run warm to the touch, this is normal. The module case is used to shunt heat from some internal components.*

We provide a number of Module mounting options and we recommend the use of these to ensure the module is mechanically secured. These include

R FR 3020 - Individual Mounting Brackets. These may be secured to any surface with mounting screws

RFR 3004 - Wall mounting bracket for 2 MiniModules. This bracket can be secured on the rear or side to any surface and will accommodate two modules. Modules mount using spring clips and can be removed and installed with no tools

RFR 3005 - 19" Rack plate for 5 MiniModules. This rack plate is designed to fit in a standard 19" rack space and is typically installed in the rear of a equipment rack. The plate is hinged to allow access to the rear of the equipment rack. Up to 5 MiniModules can be accommodated. Modules mount using spring clips and can be removed and installed with no tools. This can be used in combination with the **RFR 3010** Central power supply and control chassis to provide centralized power (with optional redundant power protection) as well as accommodation for a rack controller for connection into the LYNX centralized control system.

Please refer to the LYNX catalog or the website www.lynx-technik.com for more information on these options.

Local Control

The P MX 3362 is configured via two integral 4-position dip-switches. These are located on the top of the module and can be accessed through the cutouts provided (see below).

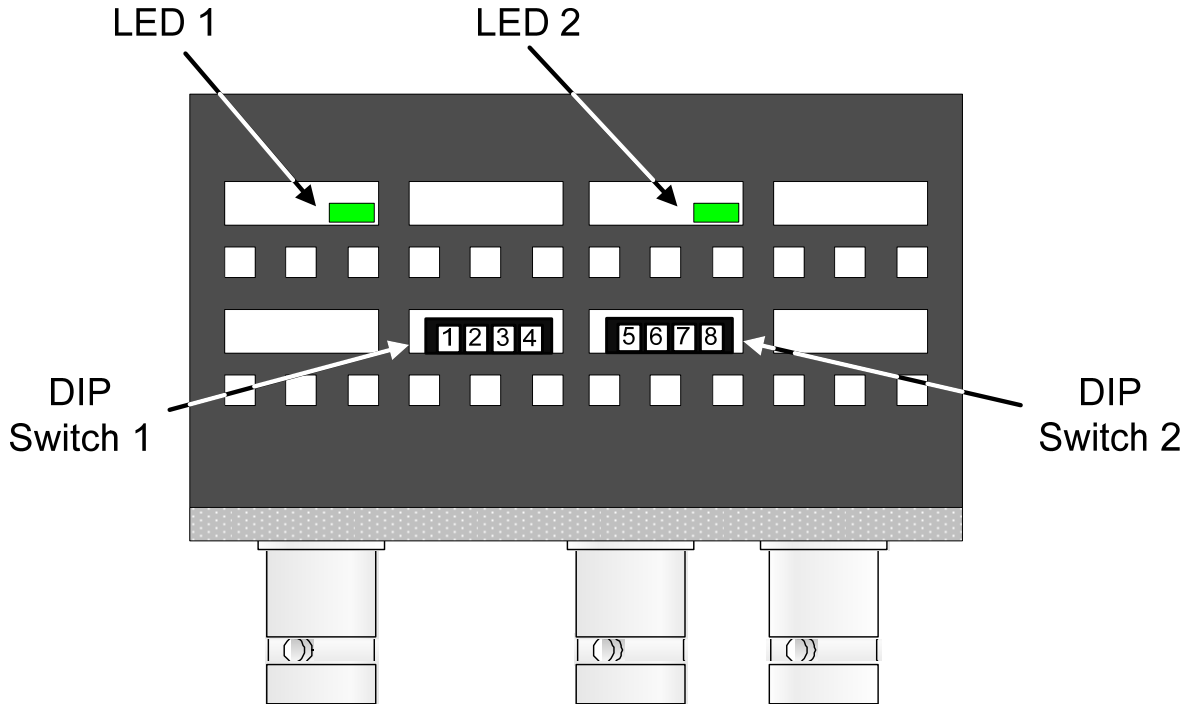

Switch Settings

Below the switch settings for the 8-position dip-switches are defined. Please see the section following the table for more detail on the switch function.

Switch	Setting	Function	
1	ON	Local adjustment enabled	
	OFF	Local adjustment disabled	
2	ON	24 Bit Audio embedding	
	OFF	20 Bit Audio embedding	
3	ON	Group deletion all groups	
	OFF	Embedded groups will pass transparently	
4 5 6	Full Scale Selection	4=OFF; 5=OFF; 6=OFF: FS=12dBu 4=ON ; 5=OFF; 6=OFF: FS=15dBu 4=OFF; 5= ON; 6=OFF: FS=18dBu 4=ON; 5=ON; 6=OFF: FS=22dBu 4=OFF; 5=OFF; 6=ON: FS=24dBu	
	7	ON	Audio embedded into Group 1 and 3
		OFF	Group 1 and 3 embedding disabled
	8	ON	Audio embedded into Group 2 and 4
OFF		Group 2 and 4 embedding disabled	

Dip Switches

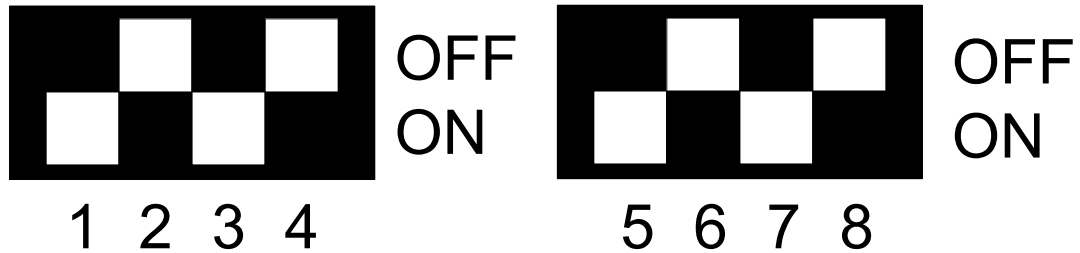

Switch Function Detail

All settings are stored in Flash Ram inside the module. Settings will be recalled on power up.

Switch 1

This switch enables local control using the dip-switches. ON enables local control and makes selections on the dipswitch active, and OFF disables local control (locking out any local changes).

Switch 2

Selection of bit width of audio for embedding: ON selects 24 Bit audio, OFF 20 Bit audio

Switch 3:

This switch activates group deletion of already embedded audio. ON makes group deletion active, i.e. all existing, embedded audio will be deleted. OFF deactivates group deletion, i.e. existing, embedded audio will transparently pass the embedder, if no new audio will be embedded into the respective group

Switch 4 to 6

Selection of Audio Full Scale Level. Five different Full Scale levels can be selected: 12, 15, 18, 22 and 24 dBu.

Dip Switch 7 and 8

The settings of these switches select the input audio for embedding into respective groups. If Dip-Switches are OFF the respective groups are disabled for embedding.

Factory Default Settings

The module is shipped with the following settings programmed. If these are the settings you require then no changes to the switch settings are required

Local Control	Enabled
Embedding	Group 1 and 2 active
Audio Bit Width	24 Bit
Auto Black	ON
Full Scale Level	15 dBu

Indicators

Alarm indicator

An Alarm indicator is provided on the front of the module (refer to module layout diagram) this LED has three states. Alarm conditions shown below.

LED Color	Status
Green	Video Present PLL Locked
Yellow	Audio missing
Red	No Signal and/or PLL unlocked

LED 1

LED1 is visible through the top of the module case (refer to module layout diagram). Conditions shown below

LED Color	Status
Green	Input SDI Present
Red	Input SDI missing

LED 2

LED2 is visible through the top of the module case (refer to module layout diagram). Conditions shown below

LED Color	Status
Green	All audio channels present
Yellow	One or more audio channels missing
Red	No Audio

Control System GUI

All LYNX CardModules support a computer interface which allows setting the modules parameters using a simple GUI interface. Access to all standard features (and in some cases) extended features is possible using this interface.

Access to the GUI requires the use of the optional LYNX control system

Note. Any settings made using the control system overrides any local settings made on the module. All settings are stored in internal flash ram and will survive power cycles and long term storage.

The GUI screenshots below are for the P MX 3362 module.

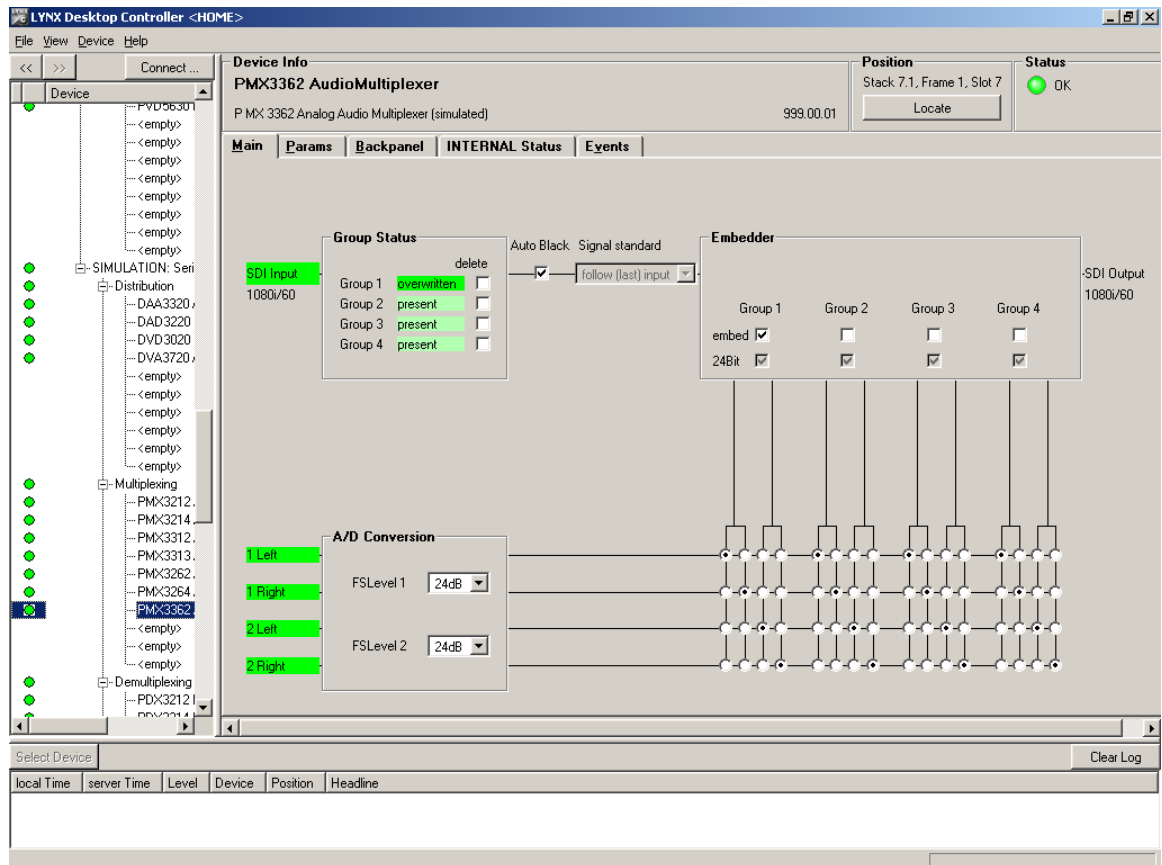

The above screenshot shows the complete module GUI. The Device info area contains information about the module including name and firmware revision. If used as part of a larger system (using the LYNX central control system) the modules position and physical location is displayed above the “locate” button.

Note. The Locate function is a tool used to quickly identify a module in larger systems. Selecting “locate” will flash the module alarm LED yellow. (does not effect module operation)

The first screen you see when the module is selected is the **Main** tab this is a graphical representation of the modules function and signal flow (left to right). Clicking on

processing boxes where shown will link to other GUI screens with controls for these specific functions.

The area at the bottom of the screen is the error log. Any fault condition will be timestamped and entered into the log.

There are a number of Tabs associated with each Module which splits up the modules settings into a number of separate screens. The primary GUI screens and functions are described below.

Main Tab

This screen is the main GUI interface and is presented first when the module is displayed in the GUI. The layout replicates module function and the signal flow if from left to right. Selections are made using onscreen sliders, radio buttons, drop down selections and checkboxes.

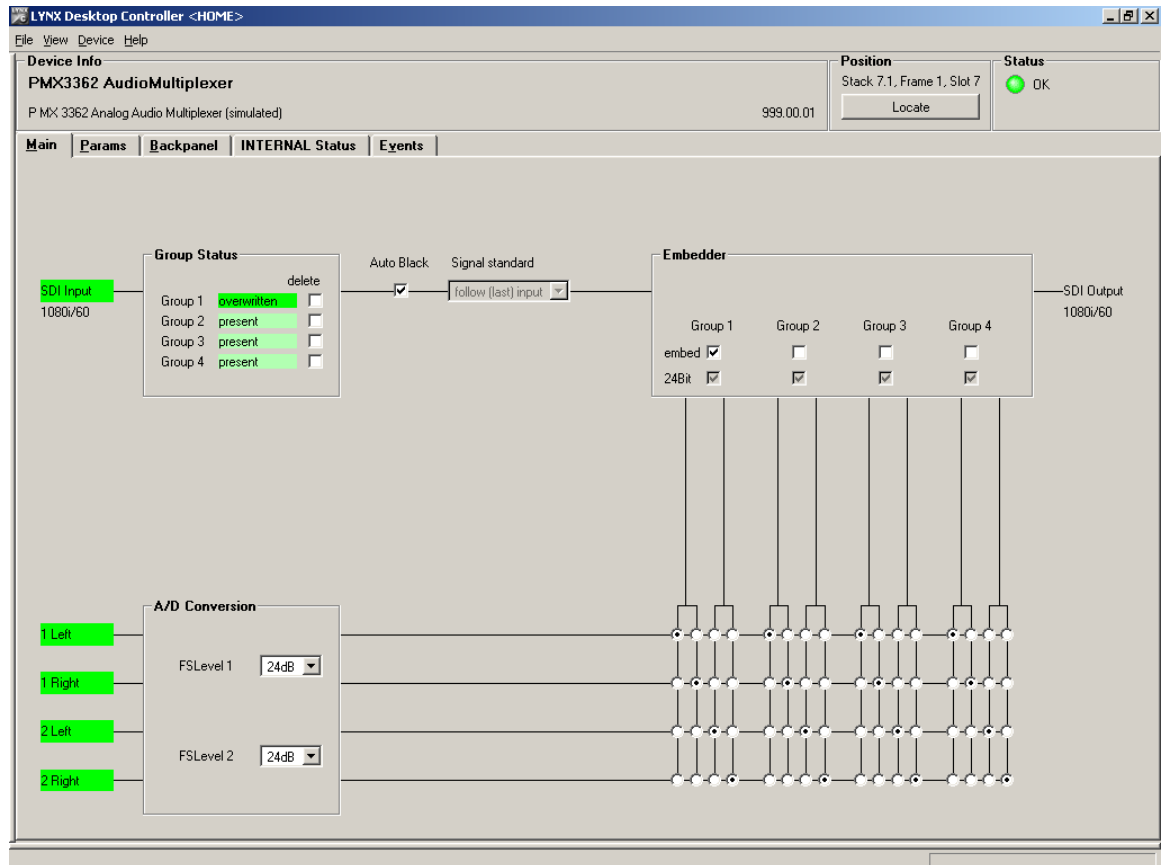

Input Detection

On the left the SDI input is detected and the standard / format displayed on screen in green (if format is not supported color = Yellow and if input is missing the color = Red)

Group Status

Any embedded audio is detected and the status is displayed in the Group Status area. If embedded audio is present it will highlight green. Its possible to delete each incoming audio group individually at this stage using the delete checkbox.

Note. *If the audio is not deleted but the group is selected for embedding then the existing audio will be over written.*

Signal Standard

This selection is grayed out when a valid input signal is detected. When there is no input (or a invalid input signal) then the selection made in this drop down box will determine the output standard of the “Black” audio sync frame for the embedder.

Default is “follow last input” which is recommended for most applications. If the video input is removed then the embedder will continue to function (with a minimal interruption to the audio embedding process) by outputting embedded audio in a black “audio sync” frame.

With no input selected its possible to preset the output format by making a selection from the drop down selections. Selections provided:

- Follow “last” input (default)
- 525
- 625
- 720P 50Hz
- 720P 60Hz
- 720P 59.94Hz
- 1080i 50Hz
- 1080i 60Hz
- 1080i 59.94Hz

Audio Analog to Digital Conversion

The Audio Full Scale Level (0 dBFS) can be set in 5 different levels: 12, 15, 18, 22 or 24 dBu.

Input Audio Crossbar

Each AES input passes into a mono crossbar where each individual left and right channel is split from the AES inputs and made available for mapping into any of the available crossbar outputs.

Embedder

The crossbar provides 8 AES outputs combined into 4 AES groups which can be embedded into the SDI input stream. Group selection is possible using the group select checkbox.

Note. *If an existing embedded group has not been deleted but is selected for embedding then the existing audio will be overwritten*

If an HDTV input signal is detected always audio signals with 24 Bit will be embedded. In case of an SDTV signal you can select in between 20 and 24 Bit embedding.

Events Tab

The Events Tab is where the module alarming and error notifications are configured for the module.

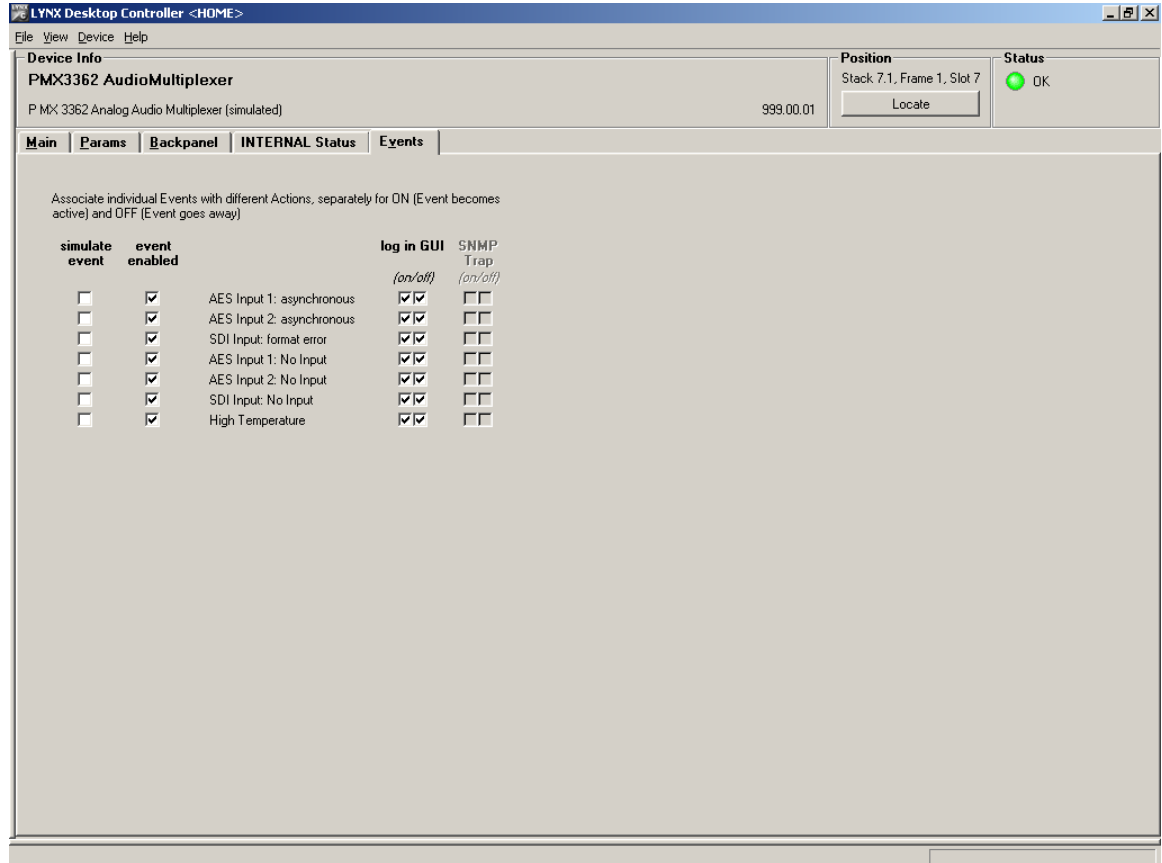

The GUI has an integrated error log, which is a simple text log file stored in the controller PC. This will record an event and timestamp it. The log can be seen at the bottom of the GUI screen and can be scrolled through using the scrolling bar.

Log in GUI Function

Events are selectable, you can chose if you want to record a particular event in the log (or not) or configure it to only record one side of the event. *(For example you might want to log when a SDI input was removed but do not want to log when it came back).* The ON/OFF trigger can be configured for each of the available events shown in the list and is setup using the checkboxes provided.

Event Enabled

By default all alarm conditions are activated (checked), by de-selecting a specific alarm condition in this column you are telling the module to ignore this condition completely. It will not color the alarm LED, log and event in the GUI or send a SNMP trap. This is useful if for example you never have anything connected to AES input 4 and want the card to ignore this input condition completely then you would simply de-select "AES 4 Input: No input" and it will be ignored.

SNMP Support

If the system is using a RCT 5030 Master Controller and the SNMP option is installed then the “SNMP Trap” columns become available.

Here you can configure for which events you would like to transmit a “SNMP trap” over the network. (This has no impact or influence over the internal error log maintained by the LYNX control system)

(Internal LYNX error logging and external SNMP traps can be configured independently).

Common GUI Controls

There are a number of GUI controls and commands which are common for all modules in the control system. These are explained below.

Right click on any module in the tree will bring up a sub-menu of available commands (see below). **Note.** This menu can also be selected using the GUI drop down menus by clicking on “**Device**”

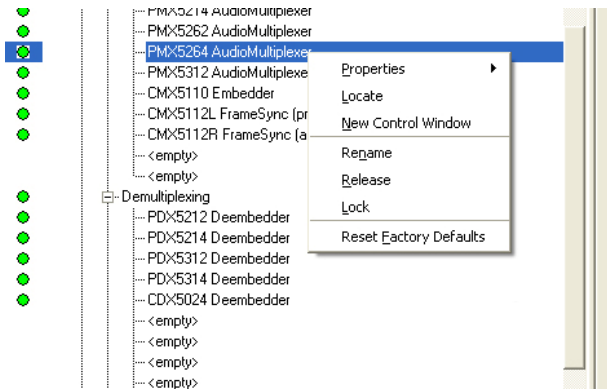

Properties

This will bring up a dialog which shows device specific properties about the module selected. (**Note.** this is just an example and the module type and data shown is not indicative of the module specified in this manual)

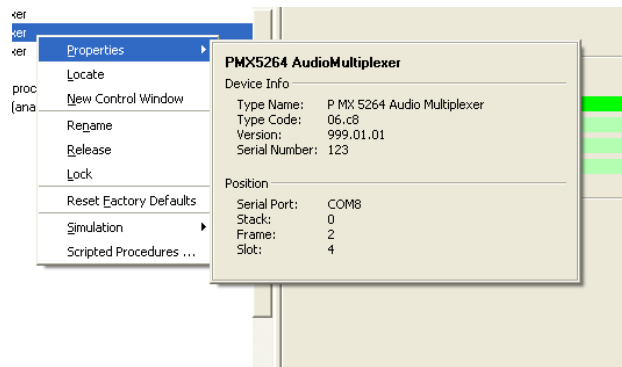

Locate

This feature is useful if you need to physically locate a module in a larger system quickly (for removal or maintenance purposes) When Locate selected this will flash the module alarm LED yellow. This function does not impact normal module operation and will timeout after a short time period.

This feature can also be invoked from the main GUI screen using the “locate“ button in the top right hand side of the screen (see below)

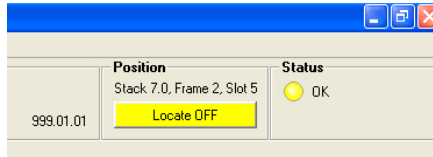

New Control Window

Selecting this will open up a new control window with selected the module GUI contained within. This window can be minimized to the taskbar for fast access and is useful if this GUI is something you will need to refer to often.

Rename

It is possible to rename everything in the control system selection tree, this includes all rack names and the individual module names. The descriptions supplied are default descriptions the system applies. To rename a device simply select the device in the tree, right click and then select “rename” the dialog below will be displayed

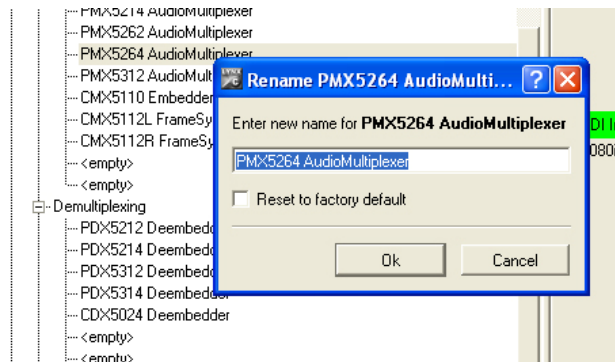

Simply type in the name you wish to assign to this device and press OK. If you wish to restore the default name simply select “Reset to Factory Default” and press OK

Release

During normal operation if there is no activity on the module GUI for approx ten seconds then any changed settings are automatically written to flash ram in the module. You can store the settings immediately by using the release command. When the settings have been stored you will see the confirmation dialog below.

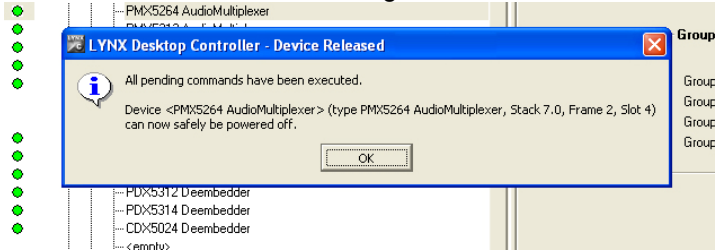

It is recommended you use the release function before removing any module from the rack to ensure the latest settings have been stored prior to module removal (if a module is removed before the normal 10 second timeout then the settings will not be stored)

Lock

Selecting this will lock the device to prevent any accidental changes being made to the modules settings. The module status can be seen but all the controls will be grayed out. To unlock simply deselect the lock control from the menu.

Reset Factory Defaults

If you are unsure of the settings, or have managed to set the module into a strange mode of operation and wish to recover the factory defaults then this can be done by selecting reset factory defaults. You will be asked to confirm this operation with the dialog below



Specifications

Video Input	
Signal Type	Serial Digital Video (SDI) SMPTE 292M, 344M, 259M with automatic input standard detection
Supported Formats	525/59.94Hz 625/50Hz 1080i/59.94Hz/60Hz/50Hz 720P/59.94Hz/60Hz/50Hz
Input Impedance	75 Ω
Input Level	0.8v
Connector	BNC
Return Loss	>15dB (270Mbits) >10dB (1.485Gbits)
Digital Video Outputs	
Signal	4 x Serial Digital Video (SDI) SMPTE 292M, 344M, 259M
Output Impedance	75 Ω
Output Level	0.8v pp +/- 10%
Return Loss	> 15dB (1.5 Ghz)
Connection	BNC
Jitter	<0.20 UI (270 Mbits) <0.25 UI (1.485Gbits)
Analog Audio Inputs	
Signal	2x balanced analog stereo inputs
Connection	25 pin Sub D
Impedance	110 Ohms
Sampling	48kHz
Quantization	24 bit
Noise floor	< -90dB (A-weighted)
Distortion	< 0.002% @ 20Hz to 20kHz
Frequency response	0.1dB @ 20Hz to 20kHz
0 dB FS level	+ 12, 15, 18, 22, 24 dBu selectable
Electrical	
Operating Voltage	+ 5 VDC
Connector	Lemo 5 pin locking connector
Power Consumption	6 W
Safety	IEC 60950 / EN 60950 / VDE 0805
Mechanical	
Size	85.5mm x 71mm x 41.5mm + connections
Weight	320g
Ambient	
Temperature	5°C – 35°C Maintaining Specifications
Humidity	80% non condensing

Service

Parts list

There are no user serviceable parts for the MiniModule. Please refer to the service section of this manual for details on how to obtain repairs.

Note

**Do not remove the covers or otherwise disassemble the MiniModule.
This will void Warranty**

Technical Support

If you are experiencing problems, or have questions please contact your local distributor for further assistance.

Technical support is also available from the LYNX website.

Please do not attempt to return products directly to LYNX without an RMA. Please contact your authorized dealer or reseller for details.

More detailed product information and product updates may be available on our web site:

www.lynx-technik.com

Contact information

Please contact your local distributor; this is your local and fastest method for obtaining support and additional sales information.

LYNX Technik can be contacted directly using the information below.

Address	LYNX Technik AG Brunnenweg 3 D-64331 Weiterstadt Germany.
Website	www.lynx-technik.com
E-Mail	info@lynx-technik.com

LYNX Technik manufactures a complete range of high quality modular products for broadcast and Professional markets, please contact your local representative or visit our web site for more product information.

